

CLUSTER **S1**



USER MANUAL

CONTENT

1. Safety Informations

| | |
|-------------------------------------------------------------|---|
| 1.1. General Preventive Measures | 3 |
| 1.2. Regulations for equipment that connects to power mains | 4 |
| 1.3. Technical warnsigns and explanation | 5 |

2. Introduction

| | |
|-----------------|---|
| 2.1. About us | 6 |
| 2.2. CLUSTER S1 | 6 |

3. General Product Information

| | |
|------------------------|---|
| 3.1. Scope of delivery | 7 |
| 3.2. Control Functions | 7 |
| 3.3. Features | 7 |

4. Installation & Setup

| | |
|---------------------------------------|----|
| 4.1 Physical Installation and Rigging | 8 |
| 4.2 Connections | 13 |
| 4.2.1. AC Power | 13 |
| 4.2.2. DMX Connection | 14 |
| 4.2.2.1. Cable Connection | 14 |

5. Operation

| | |
|---------------------------------------------|----|
| 5.1 Start up | 15 |
| 5.2 Control Display | 15 |
| 5.3 Display Short Cuts | 15 |
| 5.4 Configuration | 17 |
| 5.4.1 Set DMX Start Address (Direct Access) | 17 |
| 5.4.2 Selecting DMX Mode | 17 |
| 5.4.3 Stand Alone | 18 |
| 5.4.4 Settings | 22 |
| 5.4.5 System Info | 29 |

6. Accessories

| | |
|-----------------|----|
| 6.1 Accessories | 30 |
|-----------------|----|

7. Technical Data / Diagrams

| | |
|-------------------------------------------------|----|
| 7.1 Technical drawings and measurements | 31 |
| 7.2 IP Rating | 32 |
| 7.3 Technical Data | 33 |
| 7.4 DMX-Charts / Color Macro Charts / CCT Chart | 35 |
| 7.5 RDM Templates | 39 |
| 7.6 Firmware Update | 40 |

8. Troubleshooting

41

9. Manufacturer's Declaration

41

1. SAFETY INFORMATION

1.1. General Preventive Measures

- 1.1.1. Please read, understand and follow the instructions.
- 1.1.2. Store the instructions and information in a safe place.
Best solution is the ring binder provided by ROXX.
- 1.1.3. Follow all safety warnings. Under no circumstances remove safety warnings or other information from the equipment.
- 1.1.4. Don't use the equipment for any other intended purpose or manner.
- 1.1.5. Use only stable and compatible stands and/or brackets. Especially when fix installed.
Make sure the wall brackets are properly installed and safe. Make sure the device is securely installed and cannot fall.
- 1.1.6. Check the safety regulations applying for your country before and during installation.
- 1.1.7. Keep the device away from heat! Don't place/install near heaters, ovens or any source of heat.
Make sure that the device always is efficiently cooled and cannot overheat.
- 1.1.8. Always guarantee that ventilation and cooling slots are clean and not blocked.
- 1.1.9. Item must be away minimum 20cm from anything around and above it.
- 1.1.10. Do not use this device close to water.
- 1.1.11. Do not expose this equipment to flammable materials.
- 1.1.12. Make sure that no objects can fall into the device.
- 1.1.13. Only use this device with the accessories recommended by the manufacturer.
- 1.1.14. Always check the equipment for housing damages, so that no water can enter the device.
No containers containing liquids of any kind should be place on top of the unit.
- 1.1.15. Opening or modifying this device is only allowed by authorized and qualified persons.
- 1.1.16. All cables need to be checked after connecting the device in order to prevent damage or accidents.
- 1.1.17. Make sure that the device is transported safe and packed proper in order to prevent damage of any kind.
- 1.1.18. Once you notice improper function of your device due to damage, electric shock or anything similar,
immediately unplug the unit from the mains outlet and contact our service department.
- 1.1.19. Clean the device with a dry cloth.

- 1.1.20. Observe all disposal laws applicable in your country. Especially for the packaging.
- 1.1.21. Plastic bags are not a toy! Keep away from children!
- 1.1.22. Please note that changes or modifications which are not approved by the party responsible for compliance will void the user's authority to operate the device.

1.2 Regulations for equipment that connects to power mains

- 1.2.1. If an earthing contact is available in the used power cord, it must be used in combination with a power outlet, providing a protective ground. In no circumstances should the protective ground be deactivated.
- 1.2.2. Do not switch on the device immediately after it has been in strong different temperatures, especially after transport. Let the device acclimatize to the temperature in the room of usage first to prevent moisture and condensation.
- 1.2.3. Verify that the correct voltage and frequency are available in the area of operation, before connecting the unit to the mains outlet.
- 1.2.4. If the plug doesn't fit in your mains outlet, contact your electrician.
- 1.2.5. Make sure your power cord/adaptor/connector does not show signs of kinks/warps or is being stepped on.
- 1.2.6. Always disconnect the unit when not in use or being cleaned. Don't pull on the cord to disconnect. Only touch power connections with dry hands!
- 1.2.7. Don't switch the unit on/off rapidly. This may cause damage.
- 1.2.8. If a fuse needs to be replaced, ALWAYS make sure that exactly the same fuse will be used (type and rating). Repeatedly blown fuses need to be checked by an authorised service technician.
- 1.2.9. In the risk of lightning strike all units need to be unplugged from the mains in order to prevent damage.
- 1.2.10. During installation there must be a voltage free condition.
- 1.2.11. The device needs to be cleaned and serviced regularly and will credit this with a longer life cycle. Dust, dirt, moist, water, smoke, nicotine or anything similar inside the unit will cause damage/malfunction.
- 1.2.12. The unit needs to have at least 0,5m distance to anything flammable.
- 1.2.13. You have to make sure that any electrical installation applies to the laws of your country. Correct power cables and applying standards have to be used.

1.3. Technical warnsigns and explanation



In order to prevent the risk of an electric shock, under no circumstances remove the cover/back or open the unit in any way! No user serviceable parts are inside. Service, maintenance and repairs should only be done by qualified service personnel or the manufacturer.



Dangerous uninsulated voltage inside the device can cause an electrical shock when opened by unqualified personnel.



Important operating and maintenance instructions apply!



Do not operate this device in tropical climates.



CAUTION! Intense LED light source! Risk of eye damage. Do not look into the light source



The housing surface of the spotlight can heat up to temperatures as high as 70 °C in regular use. Ensure that it is not possible to come into contact with the housing unintentionally. Always allow sufficient time for the lamp to cool down before dismantling, carrying out maintenance work or charging etc..



IMPORTANT INFORMATION!

- This is a product which has been developed for professional usage in event technology. It is not suitable as a household lighting.
- NEVER stare, not even temporarily, directly into the light source.
- Don't use magnifiers or any other optical instrument to look at the beam.
- The effects of this device, especially the stroboscope effect, can cause problems for sensitive people or may even cause epileptical seizures.

2. INTRODUCTION

2.1. About us

The name ROXX® came easily.

Combined with the concentrated knowledge and many years of experience, our three founders, who have been leaving their mark in the event and lighting industry for many years already, came together in 2020 to start this outstanding venture.

Product development, sales and marketing as well as the exceptional know-how and the profound rooting in the field of the professional lighting technology belong to our core competences and therefore guarantee extremely innovative and reliable products, excellent support and professional service in every aspect.

Designed & developed in Germany

ROXX® products are developed and designed in Germany. Always in tight consultation with our customers and experts who will eventually be working with these tools. This ensures innovative, easy-to-use and performance-oriented solutions, which provide added value for our customers.

Made to last

Recommended for permanent outdoor use, most ROXX® products feature additional corrosion protection and enhanced IP66 equipment protection, thereby providing that crucial extra for a wider range of applications. In addition to architectural or theme park applications, even fixed installations in coastal or offshore areas with high salt exposure can be reliably implemented over long periods of time.

2.2. CLUSTER S1

Featuring 720 RGB LEDs and 288 CW LEDs, the CLUSTER S1 delivers a massive output that captivates any audience. With 26 controllable segments on both RGB and individual strobe lines, you have unparalleled control over your lighting environment. Experience seamless transitions and breathtaking effects with the continuous pixel pitch between CLUSTER S1 and S2 devices.

Designed for convenience and performance, the S1 comes equipped with a plethora of features and allows you to choose from a vast library of built-in patterns for effortless creation of stunning effects.

Whether indoors or outdoors, the IP65 rating ensures reliable operation in any environment. Say goodbye to cumbersome setups with the integrated C-Lok system, allowing for tool-free and seamless CLUSTER configurations. Pre-Link Magnets simplify alignment and operation, enabling you to focus on unleashing your creativity.

Enhance your visual repertoire with optional magnetic filters, enabling distinctive effects tailored to every light show and camera application. With multiple mounting locations, including creative rigging options and floor mounting, the S1 offers incredible flexibility in setup.

Enjoy smooth, perfect fades with 16-bit dimming control, while adjustable PWM frequencies up to 25kHz guarantee flicker-free camera operation, ensuring your visuals remain flawless in any recording scenario.

3. GENERAL PRODUCT INFORMATION

3.1. Scope of delivery

- ⊕ 1x CLUSTER S1
- ⊕ Power cord with plug (EU country specific, if not ordered differently)
- ⊕ 2x Pre-installed PUK

We're offering a wide range of professional accessories (optional). Please see under menu 6 or at our website www.roxxlight.com

3.2. Control Functions

- 12CH Simple, 27CH Easy, 44CH Standard, 138CH Pure, 269CH Pure Extended Mode, 166CH Full Access, 297CH Full Access Extended, 100CH Pure S2 Merge Mode
- Art-Net / sACN
- RDM (Remote Device Management)
- Stand Alone Functions including auto programs, LEE adjusted color macros, custom color templates and Tunable White
- Master & Slave

3.3. Features

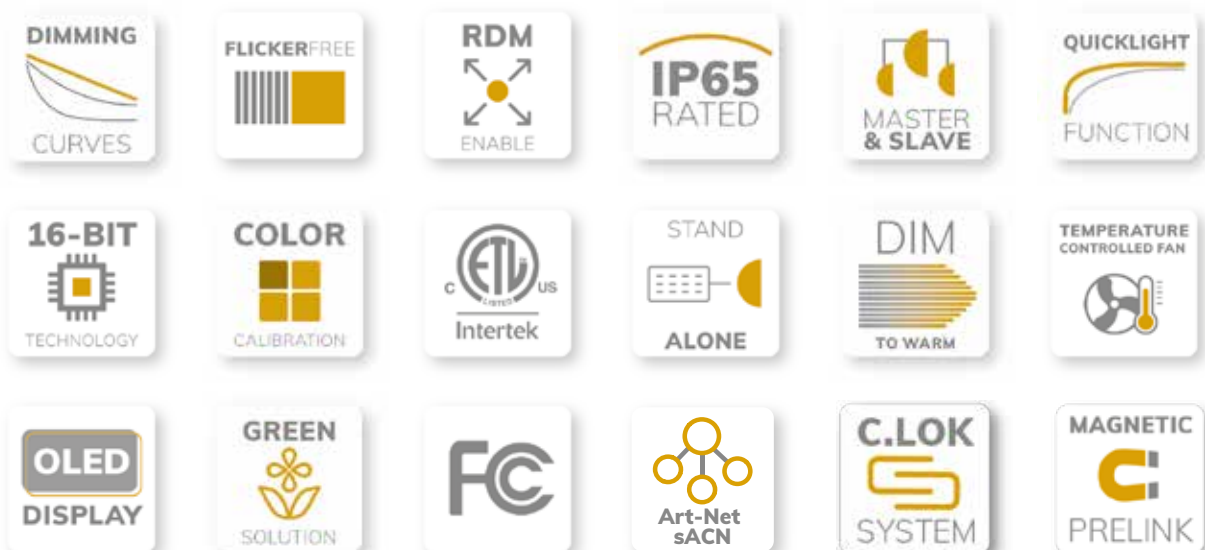

4. INSTALLATION & SETUP

4.1 Physical Installation and Rigging

ROXX CLUSTER S1 may be installed in any orientation. For this purpose the product provides several options:

Standing:

The device can be used for various floor applications. Please see the illustrations below.

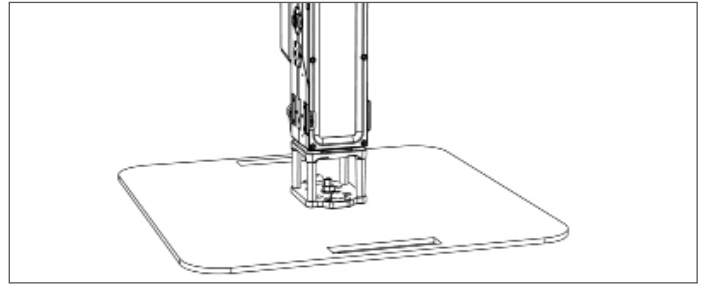
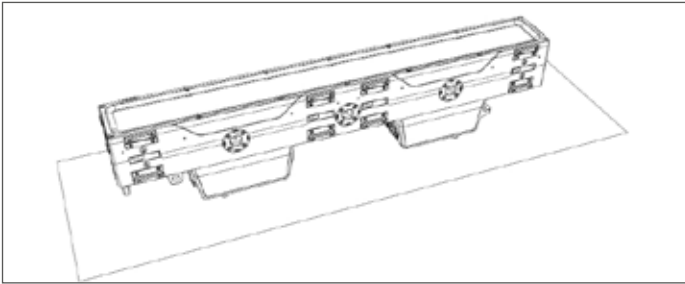
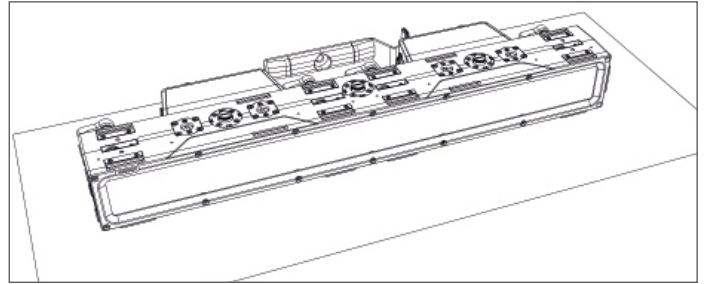
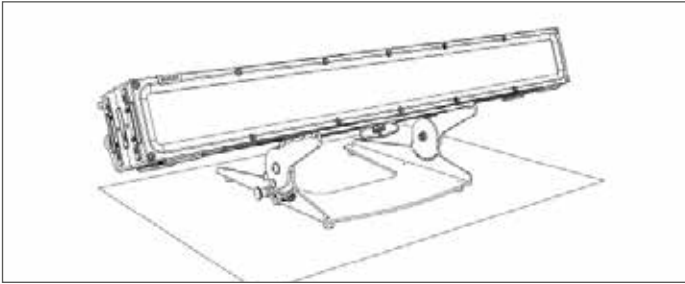

Hanging:

The fixture can be installed in different ways:

1. Directly by integrated 1/4 turn Camlocks on top- or rear side

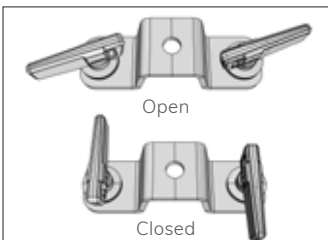
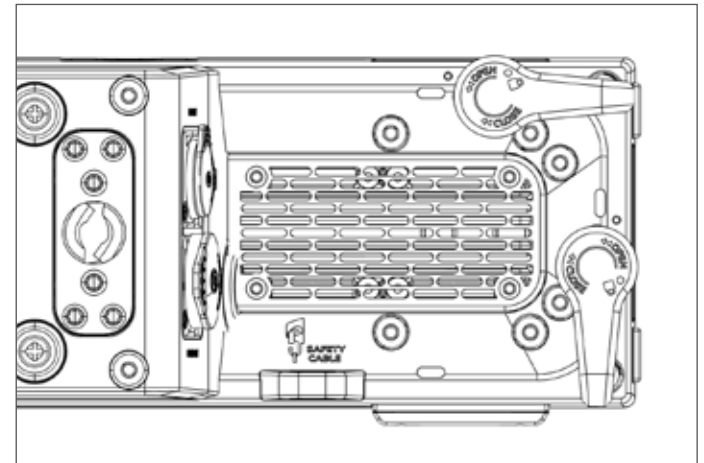
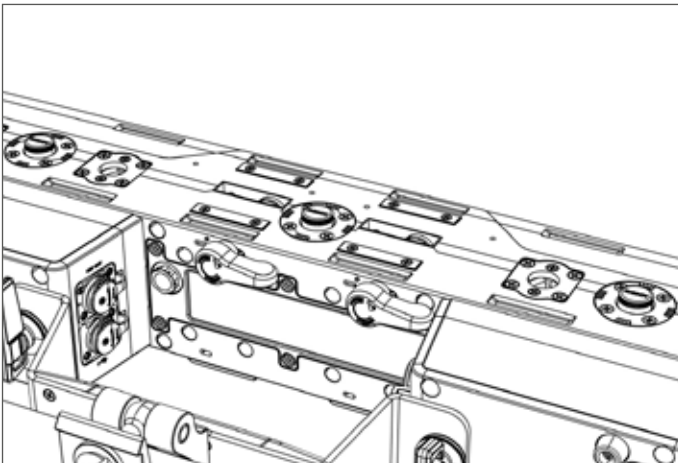

2. By optional yokes with several mounting points:

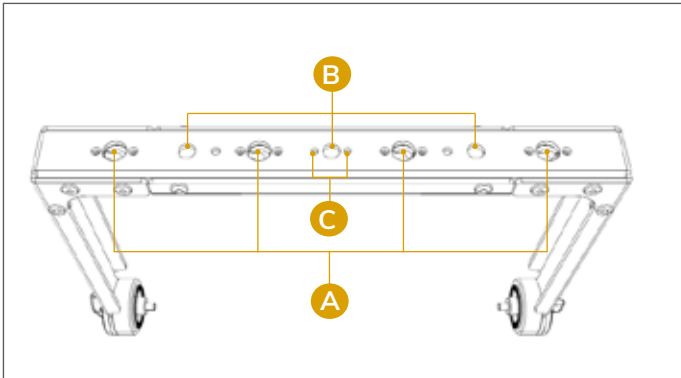

Cluster Yoke 4.2 - Multiple mounting points:
A: 3x Camlock with 1/4 turn adapters
B: 3x M12 / 1/2"
C: 1x TV Spigot

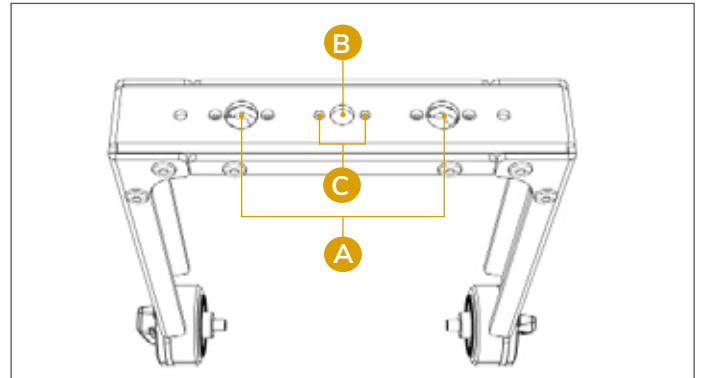

Cluster Yoke 2.2 - Multiple mounting points:
A: 1x Camlock with 1/4 turn adapters
B: 1x M12 / 1/2"
C: 1x TV Spigot

3. Using optional ROXX RIGGING BRACKET G2

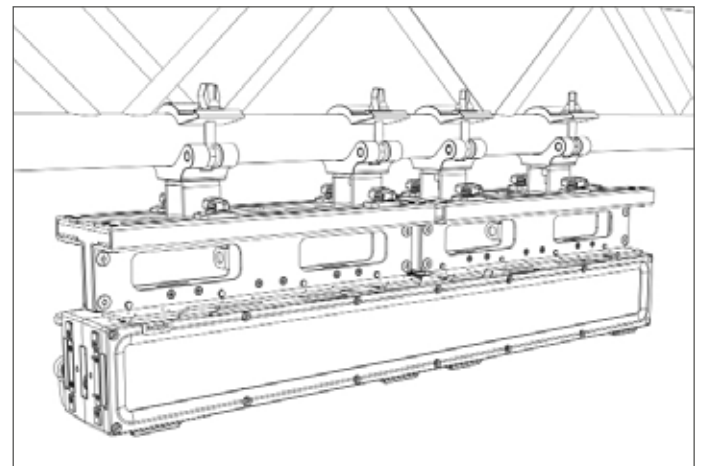
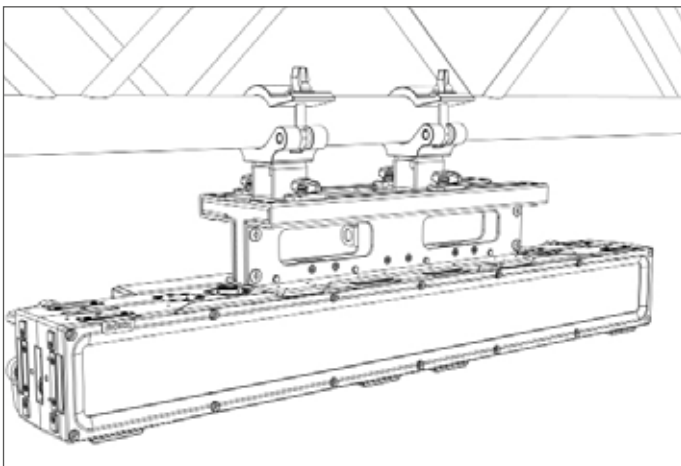

For seamless connection of multiple CLUSTER fixtures, to avoid gaps due to bracing of the truss structure by variable, sliding mounting positions.



Product Clustering

All CLUSTER products can be easily connected both horizontal and vertically, by using the integrated C-Lok system. The series is made to enable toolless multiple array configurations, scalable from a single vertical line, to massive matrix like arrays.

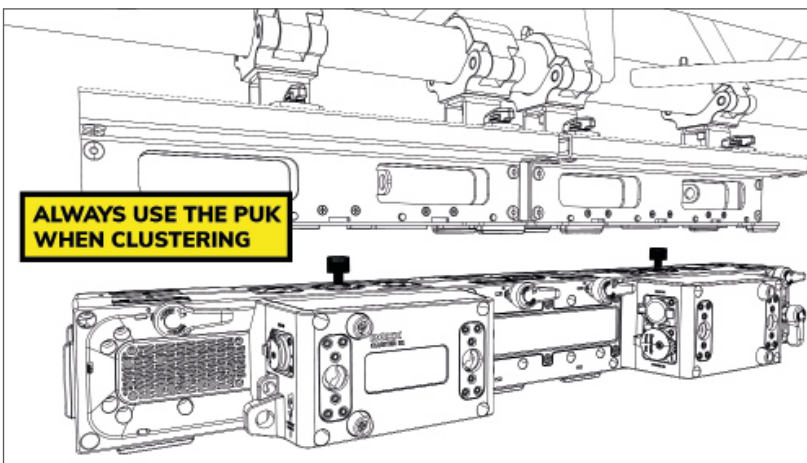

To connect the devices with each other, proceed as follows in sequence:

1. Bring the devices together with the respective top and bottom side.

A so-called centering puk is pre-installed on the top of every cluster device.

This should always be installed when connecting the devices to each other.

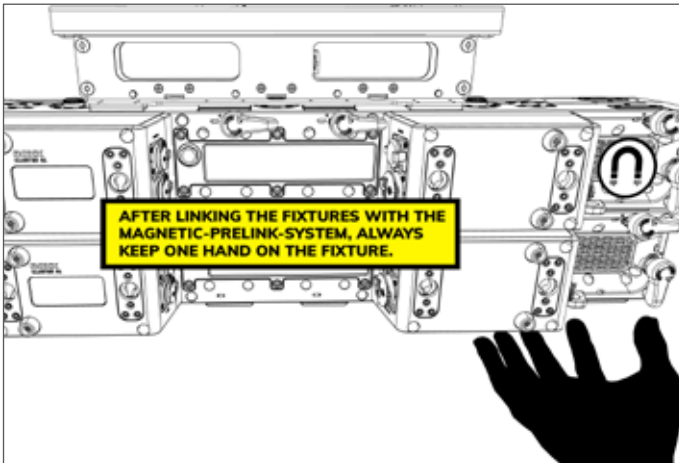

2. Pre-Link Magnets on top and side help to align the fixtures due cluster process and giving support operation for convenient and save interlocking.



Important Note:

Even though the pre-link magnet system is strong enough to hold the devices together, at least one hand must always remain on the device for support during the connection.

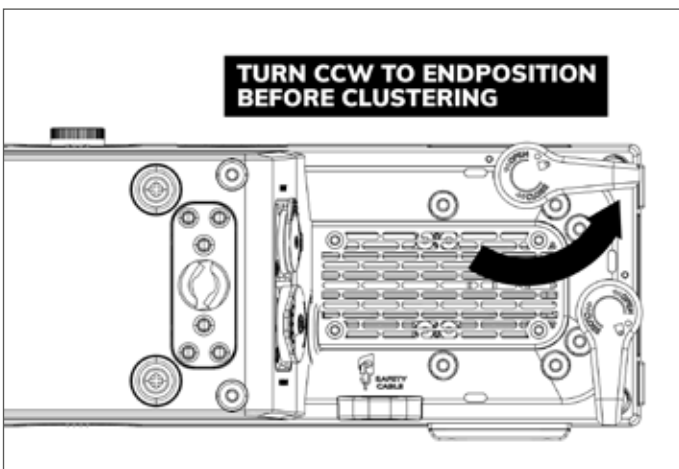

3. Make sure that the C-Lok hooks are turned counterclockwise (CCW) to the end-position first before you finally lock the C-Loks.

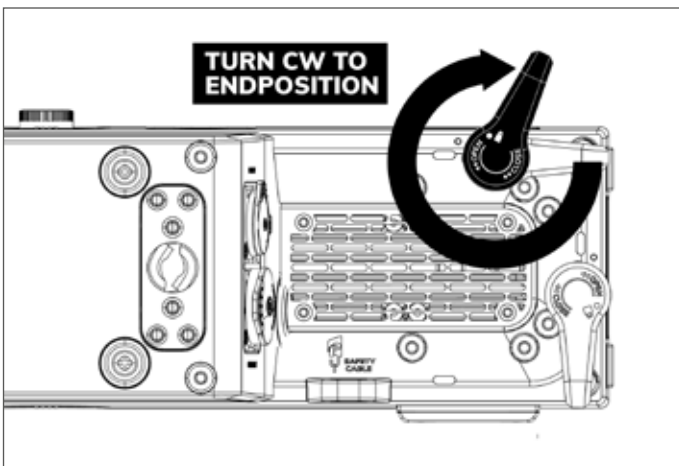

4. For locking all C-Lok's, please turn them clockwise into end-position.

Note:

As soon as both dot indicators are in line, the C-Lok is securely locked



Maximum Tensile and Torsion Load

Before setting up Cluster configurations, be aware of the maximum tensile and torsion load, listed here below. Also make sure the mounting clamps are capable of supporting the total weight of your configuration.

The different rigging options of all Cluster products result in different maximum tensile and torsion loads that must not be exceeded for a safe overhead installation.

The maximum loads listed here below take into account the 10-fold safety!

1. Rigging by integrated 1/4 turn Camlocks on top- or rear side

2. Rigging by 13mm / 1/2" centric hole on handle

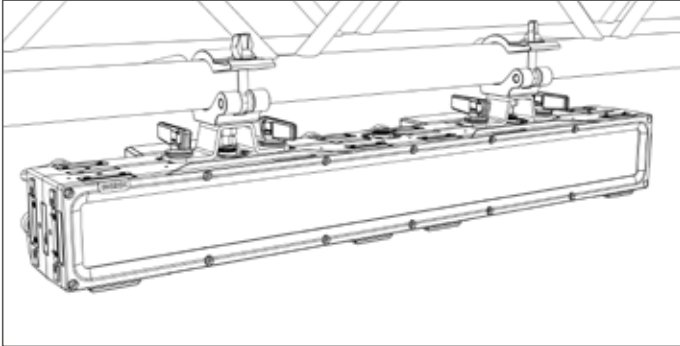

Max. Tension Load: tba / Max. Torsion Load: tba

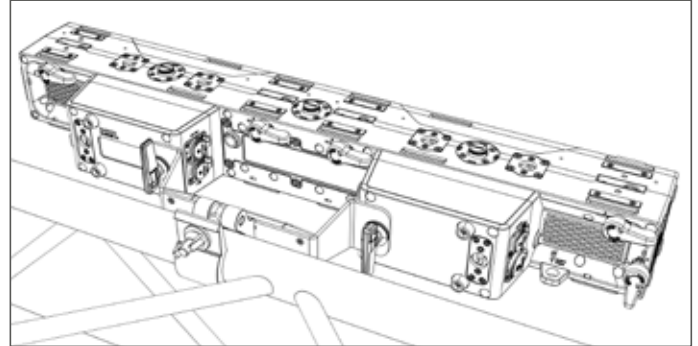

Max. Tension Load: tba / Max. Torsion Load: tba

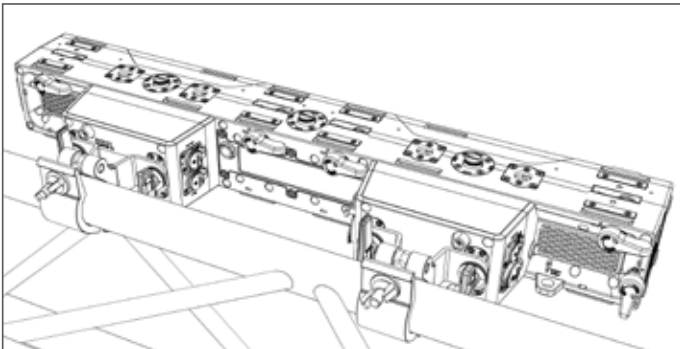

Max. Tension Load: tba / Max. Torsion Load: tba

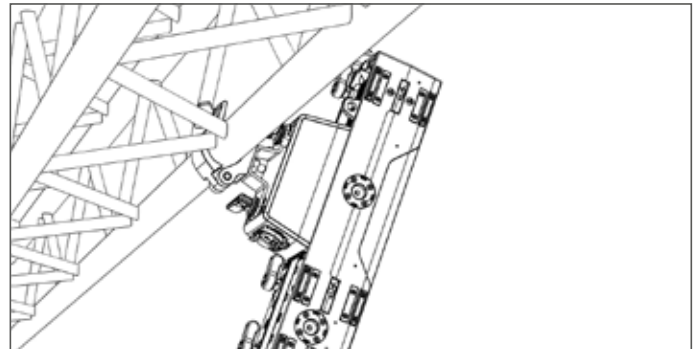

Max. Tension Load: tba / Max. Torsion Load: tba

2. Rigging by optional Yoke 4.2 and 2.2 Yoke with multiple mounting points

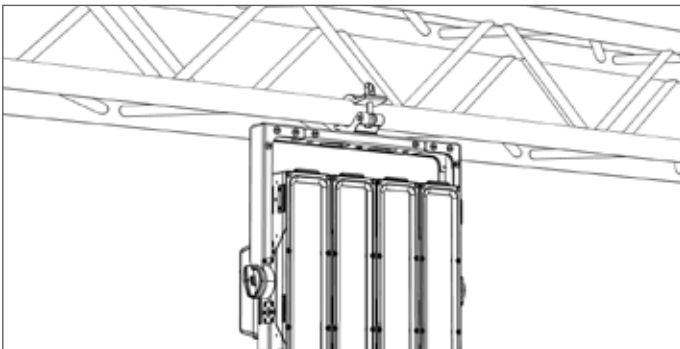

a. With 1x Mounting Clamp

Max. Tension Load: tba / Max. Torsion Load: tba

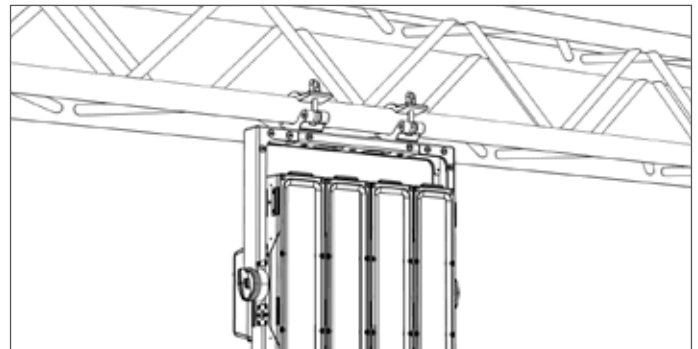

b. With 2x Mounting Clamp

Max. Tension Load: tba / Max. Torsion Load: tba

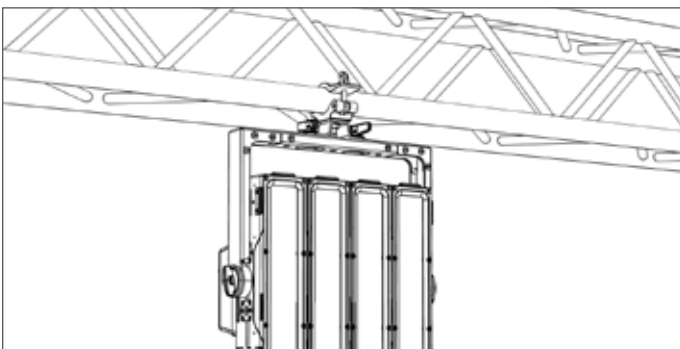

c. With 1x Omega Bracket

Max. Tension Load: tba / Max. Torsion Load: tba

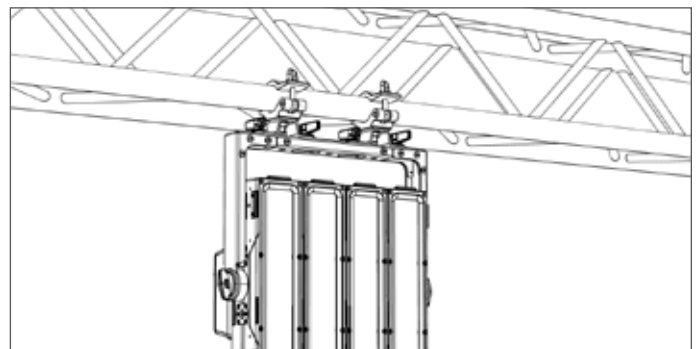

d. With 2x Omega Bracket

Max. Tension Load: tba / Max. Torsion Load: tba

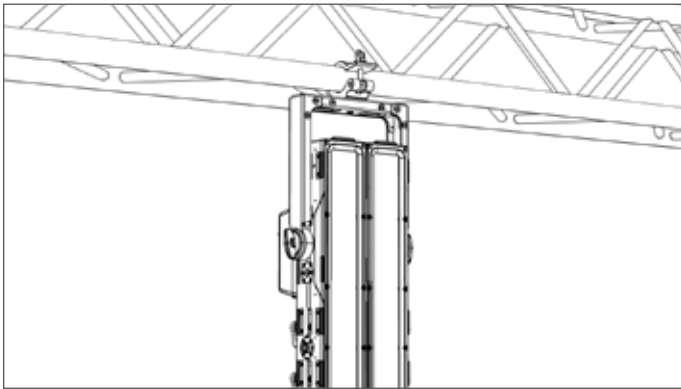

e. YOKE 2.2 with 1x Mounting Clamp

Max. Tension Load: tba / Max. Torsion Load: tba

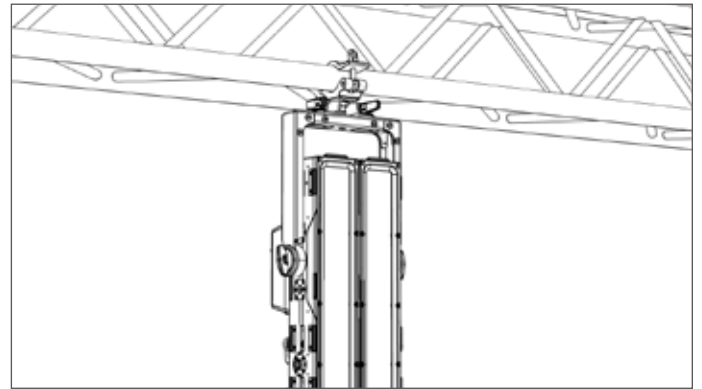

f. YOKE 2.2 with 1x Omega Bracket

Max. Tension Load: tba / Max. Torsion Load: tba

3. Using optional ROXX RIGGING BRACKET G2

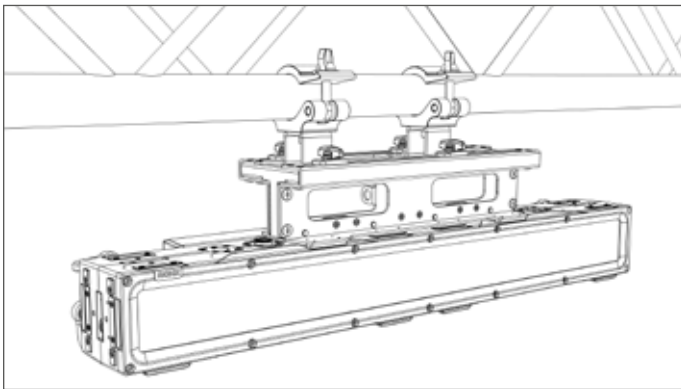

Max. Tension Load: tba / Max. Torsion Load: tba

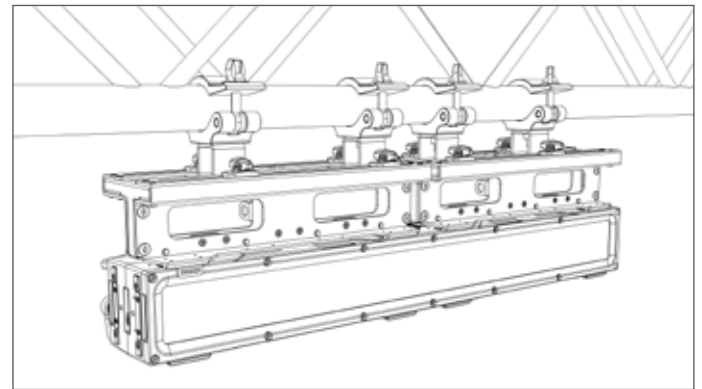

Max. Tension Load: tba / Max. Torsion Load: tba

4. Using optional ROXX VERTICAL BRACKET

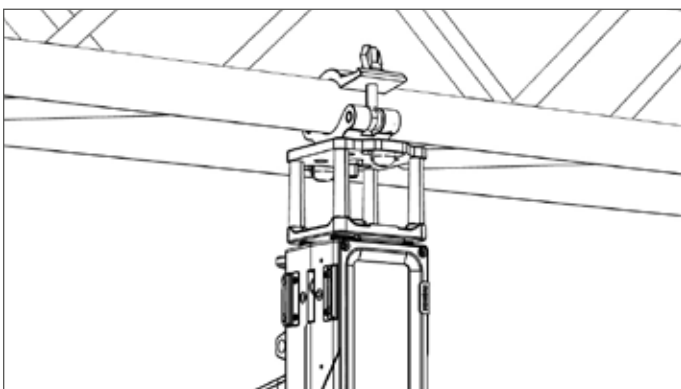

Max. Tension Load: tba / Max. Torsion Load: tba

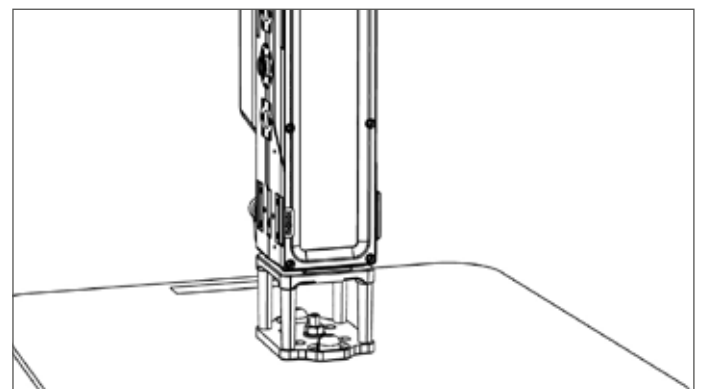

Max. Tension Load: tba / Max. Torsion Load: tba



Important Note:

Please be aware of using the centering PUK for safe RIGGING BRACKET installation to the CLUSTER device.

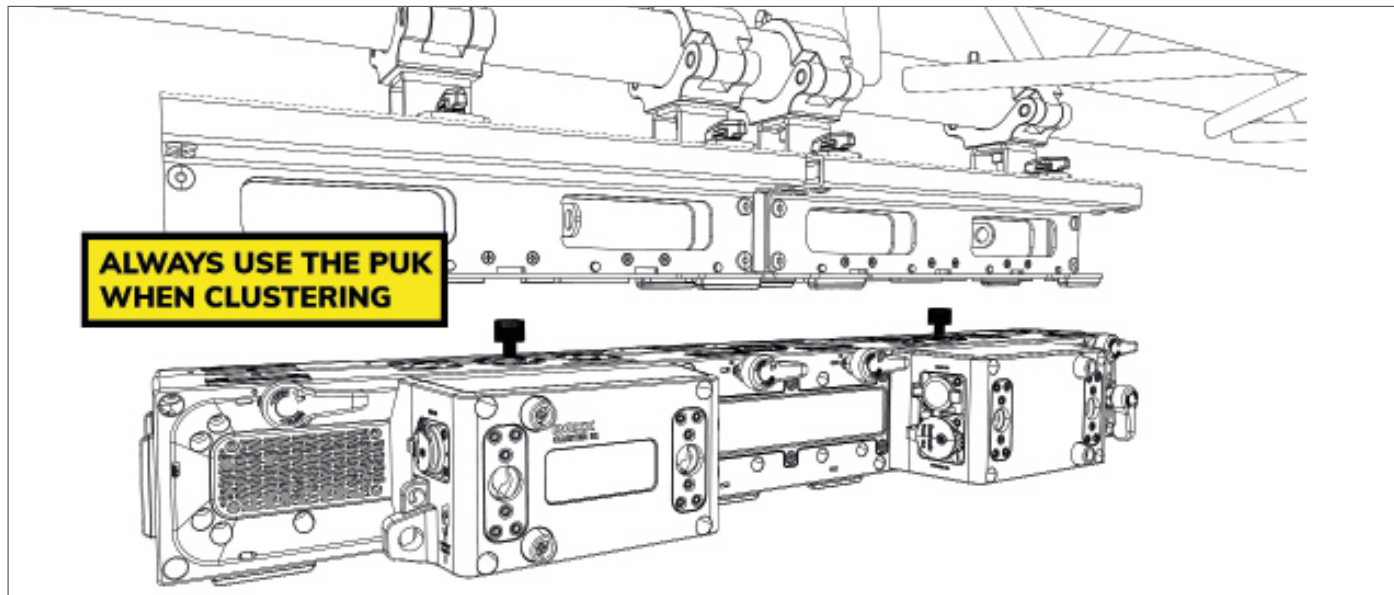

4.2 Connections*

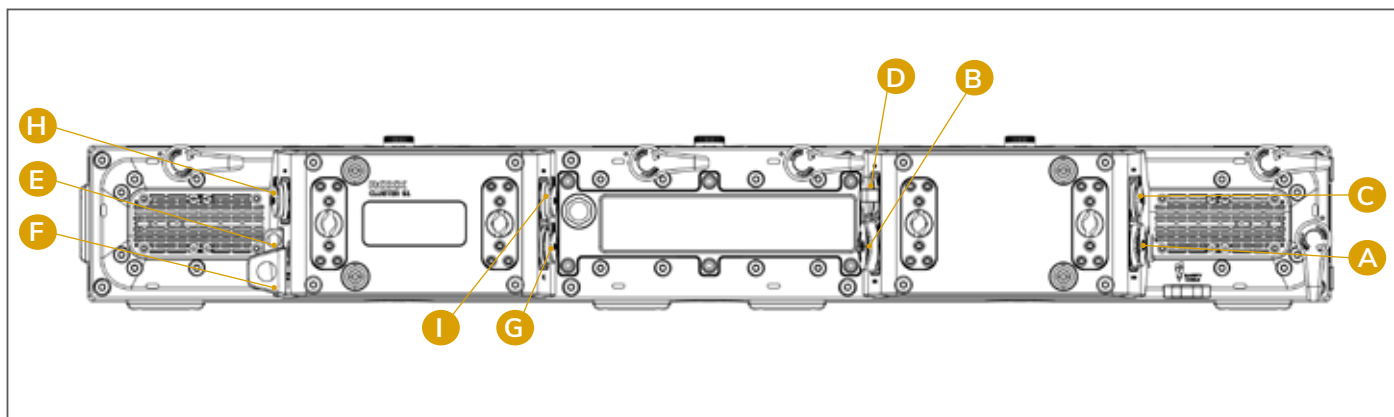

A: Mains In: IP65 Power input connector with rubber sealing cap. Connect using the provided power cable (when not in use, always close with rubber sealing cap).

B: Mains Out: IP65 Power output connector with rubber sealing cap. Provides power to additional fixtures. Ensure that the total power consumption of all daisy-chained devices connected do not exceed 8A (Ampere)! (when not in use, always close with rubber sealing cap).

C: DMX IN: Male IP65 5-pin XLR connector (when not in use, always close with rubber sealing cap).

D: DMX OUT: Female IP65 5-pin XLR connector (when not in use, always close with rubber sealing cap).

E: GoreTex

F: Safety Eyelet

G: IP65 USB port for firmware updates

H: Ethernet IN, Art-Net /sACN

I: Ethernet OUT, Art-Net /sACN

Note:

In order to provide protection from spraying water, in accordance with protection class IP65, special IP65-rated XLR connectors must be used correctly with the DMX input and output sockets, or they must be closed using the rubber sealing caps. When connected correctly, or when sealed correctly with the rubber sealing caps, the POWER IN and POWER OUT sockets are protected from spraying water, as in accordance with IP65.

4.2.1. AC Power

The CLUSTER S1 operates on any 100–260 V, 50/60 Hz AC mains power supply with a maximum power consumption of 1250W. Connect the fixture to AC power using the supplied cable or a similar one with Neutrik powerCON TRUE1 NAC3FX-W or a compatible type, to ensure the correct ingress protection (IP).

For temporary installations, the mains cable must be fitted with a grounded connector intended for exterior use. The fixture must be grounded/earthed and be able to be isolated from AC power. The AC power supply must incorporate a fuse or circuit breaker for fault protection.

| Wire Color (EU models) | Wire Color (US models) | Conductor | Symbol |
|------------------------|------------------------|----------------|--------|
| Brown | Black | Live | L |
| Blue | White | Neutral | N |
| Yellow / Green | Green | Ground (earth) | ⊕ or ⊖ |



Warning!

Read “Safety Informations” starting on page 3 before connecting the fixtures to AC mains power! Do not connect the fixture to an electrical dimmer system, as doing so may cause damage that is not covered by the product warranty!

4.2.2. DMX Connection

The CLUSTER S1 is fully controllable by DMX (USITT DMX512-A standard, based on RS-485) Art-Net, sACN and RDM.

4.2.2.1. Cable Connection

If using a cabled DMX system, connect the DMX IN cable to the input connector (male 5-pin XLR connector) and DMX OUT cable to the output (female 5-pin XLR connectors).

For outdoor installations, use only IP65-rated XLR connectors.

Use shielded twisted pair cable designed for RS-485 devices. The cables are daisy chained between the fixtures, and up to 32 fixtures can be connected to the same DMX link. Up to 300 meters (1000ft.) of cable is achievable with high quality DMX cables. All DMX links must be terminated in the last fixture by connecting a DMX termination plug to the last fixture’s 5 pin DMX out connector.

Standard microphone cable is not suitable for transmitting DMX.

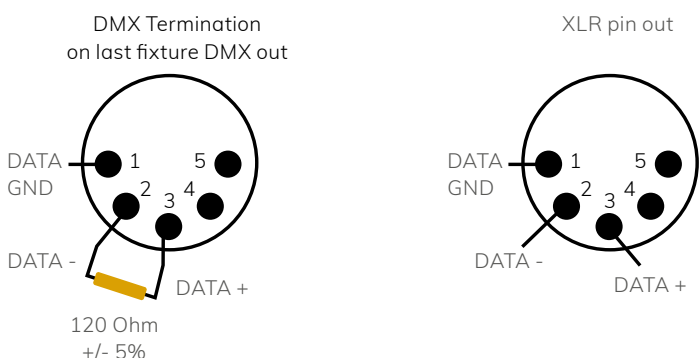

5. OPERATION

5.1 Start up*

Once the fixture is connected to AC power, the boot process starts and the following information will appear on the display:

“Ready to ROXX”, the product name and the current software version.



After this process, the fixture is ready for operation, and starts in the previously enabled mode.

***Note:**

During boot process the fan spins up quickly to blow out some possible dust from last use.

5.2 Control Display*

OLED Display with Touch-Sensitive controls



Press **ENTER** to access the selection menu for system settings or confirm changes.



Press **ESC** to take a step back in the menu.



Press **arrows to scroll up and down** inside the menu and change values, such as DMX address.

***Note:**

For a smooth navigation thru the menu settings, please make sure the display surface is dry and dust free.

After approximately 1 minute of inactivity inside the menu settings, the display will automatically jump back to home screen.

5.3 Display Short Cuts*

Short Cuts

For some always recurring functions the fixture allows quick and user-friendly access at home screen over some display control short-cuts:

User Reset or Factory Reset*



Pressing **ESC+ENTER** simultaneously a Factory Reset or User Reset can be started.

By using the up/down arrows the Factory- or User Reset can be selected.

For confirming press **ENTER**, to jump back please press **ESC**.

***Note:**

After Factory Reset all fixture settings are set back to factory default values.

After User Reset all user selected reset functions and user default values will set back.

Also a short self-test will start immediately while dimming in and out each single color.

Display Off



Pressing ESC + arrow down simultaneously the display backlight function will set to off and the display will turn off immediately. Once a control is pressed the display backlight will turn on.

Manual display flip function*



The fixture includes an auto display flip function by default.

To use the manual display flip function please disable the auto flip function under Settings / Display first. Once the auto display flip function is disabled you can use the manual display flip function by pressing arrow up + arrow down simultaneously. The display will rotate 180. By pressing both arrows simultaneously again the display will flip back.

*Note:

Once the display is flipped both Up / Down controls will work according to the display rotation.

Quick Light function

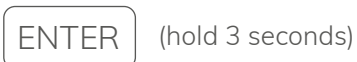

For easy and fast operation during setting the lights the fixture includes a user-friendly Quick Light function (Daylight 5600 Kelvin). If DMX is not assigned please press and hold ENTER for 3 seconds at homescreen, after the Quick Light function will appear.

Here dimmer can be adjusted from 0-100% by using up/down arrows, to take over the dimming value please press ENTER to confirm.

5.4 Configuration

Home Screen

After boot process the fixture is ready for operation and starts in the previously enabled mode. At home screen the following information will appear, depending on the current operating mode:

- A DMX Address
- B Operating Mode (DMX Mode, Quick Light or Standalone Mode)
- C Next available DMX address depending on the fixtures DMX footprint
- D External Data protocol (DMX / Art-Net / sACN).
- E The dot indicates the active protocol

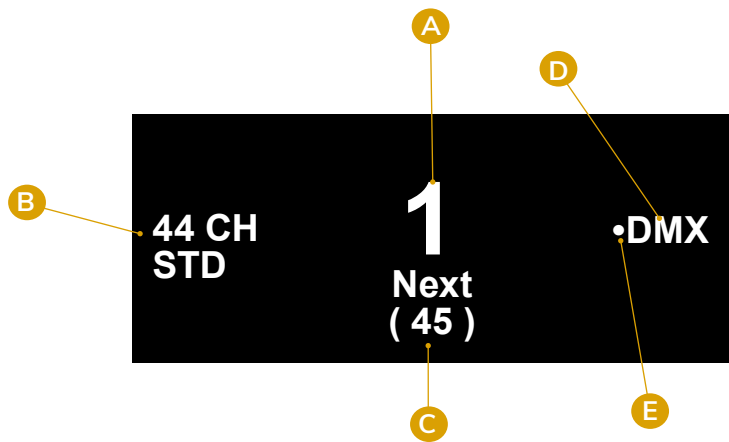

5.4.1 Set DMX Start Address (Direct Access)

At Home Screen the DMX address can be changed directly by using the up and down arrows. During this process the DMX address starts blinking, once it's confirmed by pressing ENTER it stops blinking.

If the DMX address will not be confirmed by ENTER within 10 seconds, the display will jump back and show the DMX address from before and stops blinking.

5.4.2 Selecting DMX Mode*

At home screen please press ENTER to access to the main menu (level 1).

While using UP / DOWN arrows, please select the menu item "DMX Mode" and confirm by pressing ENTER.

In the following sub-menu (level 2), you can now choose between 7 different DMX operating modes while using the UP/Down arrows and confirm by pressing ENTER or jump back by pressing ESC.

After confirmation the display will jump back to main menu (level 1). Press ESC for homescreen, here the selected DMX mode will be displayed.

① *Note:

For detailed information about the several DMX modes including channel assignment please see our DMX Control chart.

Level 1

| Menu |
|--------------------------------------------------------------------------------------------------------------------------|
| <ul style="list-style-type: none"> ➤ DMX Mode Stand Alone Settings System Info |

Level 2

| DMX Mode |
|--------------------------------------------------------------------------------------------------------------------------------------------------------------------------------------------------------------------------------------------------------|
| <ul style="list-style-type: none"> ➤ 12CH Simple 27CH Easy 44CH Standard 138CH Pure 269CH Pure Extended 166CH Full Access 297CH Full Access Extended 100CH Pure S2 Merge |

5.4.3 Stand Alone*

Press ENTER to access to main menu (level 1).

While using the UP / DOWN arrows, please select the menu item “Stand Alone” and confirm by pressing ENTER.

In the following sub-menu (level 2), you can now choose between 5 different Stand Alone operating modes (Auto, Color Macro, Quick Color, Tunable White, User Color) ,Stop Stand Alone and Color Settings functions while using the UP/Down arrows and confirm by pressing ENTER or jump back by pressing ESC.

To finally use Stand Alone programs please make sure DMX is disconnected to the fixture, as this protocol has priority.

Stop Stand Alone

To stop a running Stand Alone mode immediately, please select “Stop Stand Alone” and confirm by pressing ENTER. The display will automatically jump back to level 1.

Level 1

| Menu |
|--------------------------------------------------------------------------------------------------------------------------|
| <ul style="list-style-type: none"> DMX Mode ➤ Stand Alone Settings System Info |

Level 2

| Stand Alone Mode |
|----------------------------------------------------------------------------------------------------------------------------------------------------------------------------------------------------|
| <ul style="list-style-type: none"> ➤ Stop Stand Alone Auto FX Color Macro Quick Color Tunable White User Color Color Settings |

Auto FX*

Select “Auto FX” by using the up/down arrows and press ENTER.

Here at sub-menu (level 3), you can choose between 10 different Auto Effects (Effect 1 - 10) and Stop Program. Using the Up/Down arrows you can select one of the 10 Effects and confirm by pressing ENTER or step back by ESC.

After confirming your preferred Effect, you can now adjust speed and brightness at level 4.

To adjust speed, please use the UP / DOWN arrows to select the menu item “Speed”, and confirm with ENTER. After use UP / DOWN arrows to adjust the speed value between 000-100 and confirm by ENTER or jump back by ESC.

To adjust brightness please select “Dim” as per the procedure previously described and confirm with ENTER. After use UP / DOWN arrows again to adjust the brightness value between 000-100 and confirm by ENTER or jump back by ESC.

Once it’s confirmed or denied the display will automatically jump back to level 3.

To stop running a selected Effect please chose “Stop Program” at level 3 or "Stop Stand Alone" at level 2.

For returning back to homescreen please press ESC three times.

At homescreen the selected Stand Alone mode “Auto” and the selected program will be displayed.

ⓘ *Note: Using arrows UP /DOWN at homescreen Auto programs can be directly changed according to the list.

Level 1

| Menu |
|---------------|
| DMX Mode |
| ➤ Stand Alone |
| Settings |
| System Info |

Level 2

| Stand Alone Mode |
|------------------|
| Stop Stand Alone |
| ➤ Auto FX |
| Color Macro |
| Quick Color |
| Tunable White |
| User Color |
| Color Settings |

Level 3

| Auto |
|----------------|
| ➤ Stop Program |
| Effect 1 |
| Effect 2 |
| Effect 3 |
| Effect 4 |
| Effect 5 |
| Effect 6 |
| Effect 7 |
| Effect 8 |
| Effect 9 |
| Effect 10 |

Level 4

| Program |
|---------------------|
| ➤ Speed <0-100> |
| (Default 50) |
| Dim <0-100> |

Auto FX Effect 1

Color Macro*

46 different color macros (34x matched LEE color filters, 6 LED colors and 6 different Whites) are available as presets. For each the brightness can be adjusted separately.

Level 1

| Menu |
|---------------|
| DMX Mode |
| ➤ Stand Alone |
| Settings |
| System Info |

Level 2

| Stand Alone Mode |
|------------------|
| Stop Stand Alone |
| Auto FX |
| ➤ Color Macro |
| Quick Color |
| Tunable White |
| User Color |
| Color Settings |

Level 3

| Color Macro |
|-------------------|
| Color Off |
| ➤ Color Macros |
| Color Macro Chart |
| Dim <0-100> |

To select a color macro please press ENTER to access to main menu (level 1).

While using the UP / DOWN arrows select the menu item "Stand Alone" and confirm

by pressing ENTER. After please select the item "Color Macro" by using the up/down arrows and press ENTER again.

Using UP and DOWN controls, select your desired color preset and confirm with ENTER.

At level 3 you can adjust the brightness for the color preset between 000-100. Confirm by ENTER. For color blackout choose the item "Color Off".

Note: Using UP / DOWN arrows at homescreen Color Macros can be changed according to the list.

Level 4

| Gels - Color Macros for Standalone Mode | | | Gels - Color Macros for Standalone Mode | | | Gels - Color Macros for Standalone Mode | | |
|-----------------------------------------|-------------------|----------------|-----------------------------------------|----------------|---------------|-----------------------------------------|---------------------------|----------------|
| Pos. | Gel Name | Color Number | Pos. | Gel Name | Color Number | Pos. | Gel Name | Color Number |
| 1 | Red | 100% Red LED | 17 | Jade | LEE 323 | 33 | Special Med Lavender | LEE 343 |
| 2 | Fire | LEE 019 | 18 | Blue | 100% Blue LED | 34 | Ultimate Violet | LEE 707 |
| 3 | Medium Red | LEE 027 | 19 | Sky Blue | LEE 068 | 35 | Magical Magenta | LEE 795 |
| 4 | Primary Red | LEE 106 | 20 | Tokyo Blue | LEE 071 | 36 | Chrysalis Pink | LEE 798 |
| 5 | Med Amber | LEE 020 | 21 | Light Blue | LEE 118 | 37 | Specia KH Lavender | LEE 799 |
| 6 | Dark Amber | LEE 022 | 22 | Marine Blue | LEE 131 | 38 | Bulb White | 2700K |
| 7 | Deep Amber | LEE 104 | 23 | Med Blue | LEE 132 | 39 | Halogen White | 3200K |
| 8 | Orange | LEE 105 | 24 | Congo Blue | LEE 181 | 40 | Neutral White | 4200K |
| 9 | Deep Golden Amber | LEE 135 | 25 | Mikkel Blue | LEE 716 | 41 | Daylight White | 5600K |
| 10 | Yellow | LEE 101 | 26 | Rose Pink | LEE 002 | 42 | Cold White I | 6000K |
| 11 | Green | 100% Green LED | 27 | Med Pink | LEE 036 | 43 | Cold White II | 6300K |
| 12 | Lime Green | LEE 088 | 28 | Light Lavender | LEE 052 | 44 | Amber (only if available) | 100% Amber LED |
| 13 | Moss Green | LEE 089 | 29 | Lavender | LEE 058 | 45 | Lime (only if available) | 100% Lime LED |
| 14 | LEE Green | LEE 121 | 30 | Magenta | LEE 113 | 46 | Cyan (only if available) | 100% Cyan LED |
| 15 | Primary Green | LEE 139 | 31 | Mauve | LEE 126 | | | |
| 16 | Jas Green | LEE 738 | 32 | Smokey Pink | LEE 127 | | | |

Quick Color*

The standalone mode “Quick Color” allows a direct adjustment of the single LED segments, Dimmer and Shutter.

Level 1

| Menu |
|---------------|
| DMX Mode |
| ➤ Stand Alone |
| Settings |
| System Info |

Level 2

| Stand Alone Mode |
|------------------|
| Stop Stand Alone |
| Auto FX |
| Color Macro |
| ➤ Quick Color |
| Tunable White |
| User Color |
| Color Settings |

Level 3

| Quick Color |
|-----------------------------|
| Dimmer Single Tubes <0-100> |
| Dimmer RGB Panel <0-100> |
| Shutter <0-255> |
| Red <0-255> |
| Green <0-255> |
| Blue <0-255> |

To adjust your Quick Color please press ENTER to access to main menu (level 1).

While using the UP / DOWN arrows select the menu item “Stand Alone” and confirm

by pressing ENTER. After please select the item “Quick Color” by using the up/down arrows and press ENTER again.

Using UP and DOWN controls, select your desired LED segment or color and confirm with ENTER.

After you can adjust the brightness for the color between 000-255 and confirm by ENTER.

Besides the individual color mix also a master dimmer can be adjusted between 000-100.

For strobe effects please adjust the Shutter value between 000-255.

ⓘ *Note: Please see detailed explanation for strobe effects inside DMX chart at the end of this manual.

Using UP/DOWN arrows at homescreen you can change Quick Color’s dimmer value.

Tunable White*

The standalone mode “Tuneable White” allows the color temperature (CCT) to be adjusted from 2.000K – 10.000K in 100K steps and affects both RGB panels only. Besides brightness and shutter also a +/- green and magenta correction is available.

| Level 1 | Level 2 | Level 3 | | | | | | | | | | | | | | | | | | |
|--------------------------------------------------------------------------------------------------------------------------------------------------------------------------------------------------------------------|---------|----------|---------------|----------|-------------|-------------------------------------------------------------------------------------------------------------------------------------------------------------------------------------------------------------------------------------------------------------------------------------------------------------------------------------------|------------------|------------------|---------|-------------|-------------|-----------------|------------|----------------|-----------------------------------------------------------------------------------------------------------------------------------------------------------------------------------------------------------------------------------------------------------------------|---------------|------------|---------------------|----------------|-----------------|
| <table border="1"> <thead> <tr> <th>Menu</th> </tr> </thead> <tbody> <tr> <td>DMX Mode</td> </tr> <tr> <td>█ Stand Alone</td> </tr> <tr> <td>Settings</td> </tr> <tr> <td>System Info</td> </tr> </tbody> </table> | Menu | DMX Mode | █ Stand Alone | Settings | System Info | <table border="1"> <thead> <tr> <th>Stand Alone Mode</th> </tr> </thead> <tbody> <tr> <td>Stop Stand Alone</td> </tr> <tr> <td>Auto FX</td> </tr> <tr> <td>Color Macro</td> </tr> <tr> <td>Quick Color</td> </tr> <tr> <td>█ Tunable White</td> </tr> <tr> <td>User Color</td> </tr> <tr> <td>Color Settings</td> </tr> </tbody> </table> | Stand Alone Mode | Stop Stand Alone | Auto FX | Color Macro | Quick Color | █ Tunable White | User Color | Color Settings | <table border="1"> <thead> <tr> <th>Tunable White</th> </tr> </thead> <tbody> <tr> <td>CCT <5600></td> </tr> <tr> <td>TINT <000> (+/-127)</td> </tr> <tr> <td>Dimmer <0-255></td> </tr> <tr> <td>Shutter <0-255></td> </tr> </tbody> </table> | Tunable White | CCT <5600> | TINT <000> (+/-127) | Dimmer <0-255> | Shutter <0-255> |
| Menu | | | | | | | | | | | | | | | | | | | | |
| DMX Mode | | | | | | | | | | | | | | | | | | | | |
| █ Stand Alone | | | | | | | | | | | | | | | | | | | | |
| Settings | | | | | | | | | | | | | | | | | | | | |
| System Info | | | | | | | | | | | | | | | | | | | | |
| Stand Alone Mode | | | | | | | | | | | | | | | | | | | | |
| Stop Stand Alone | | | | | | | | | | | | | | | | | | | | |
| Auto FX | | | | | | | | | | | | | | | | | | | | |
| Color Macro | | | | | | | | | | | | | | | | | | | | |
| Quick Color | | | | | | | | | | | | | | | | | | | | |
| █ Tunable White | | | | | | | | | | | | | | | | | | | | |
| User Color | | | | | | | | | | | | | | | | | | | | |
| Color Settings | | | | | | | | | | | | | | | | | | | | |
| Tunable White | | | | | | | | | | | | | | | | | | | | |
| CCT <5600> | | | | | | | | | | | | | | | | | | | | |
| TINT <000> (+/-127) | | | | | | | | | | | | | | | | | | | | |
| Dimmer <0-255> | | | | | | | | | | | | | | | | | | | | |
| Shutter <0-255> | | | | | | | | | | | | | | | | | | | | |

Starting from home screen press ENTER to access to main menu (level 1).

While using the UP / DOWN arrows select the menu item “Stand Alone” and confirm by pressing ENTER.

After please select the item “Tunable White” by using the up/down arrows and press ENTER again.

Using UP and DOWN controls to select your desired menu item, confirm by ENTER and adjust the desired value by up and down controls and confirm all entries with ENTER.

ⓘ *Note:

Tint values

- 000** = no function/neutral
- 001 - 127** = + green
- 001 to - 127** = - green

ⓘ *Note: Using UP/DOWN arrows at homescreen the selected CCT value can be changed in +/- 100K steps.

Shutter: Please see detailed explanation for strobe effects inside DMX chart at the end of this manual.

User Color*

The standalone mode “User Color” allows to store up to 5 customized color presets out of Red, Green, Blue, brightness and shutter.

| Level 1 | Level 2 | Level 3 | Level 4 | | | | | | | | | | | | | | | | | | | | | | | | | |
|--------------------------------------------------------------------------------------------------------------------------------------------------------------------------------------------------------------------|---------|----------|---------------|----------|-------------|-------------------------------------------------------------------------------------------------------------------------------------------------------------------------------------------------------------------------------------------------------------------------------------------------------------------------------------------|------------------|------------------|---------|-------------|-------------|---------------|--------------|----------------|------------------------------------------------------------------------------------------------------------------------------------------------------------------------------------------------------------------------------------------|------------|---------|---------|---------|---------|---------|------------------------------------------------------------------------------------------------------------------------------------------------------------------------------------------------------------------------------------------------------------------------------------------------------|------------|----------------|-----------------|-------------|---------------|--------------|
| <table border="1"> <thead> <tr> <th>Menu</th> </tr> </thead> <tbody> <tr> <td>DMX Mode</td> </tr> <tr> <td>█ Stand Alone</td> </tr> <tr> <td>Settings</td> </tr> <tr> <td>System Info</td> </tr> </tbody> </table> | Menu | DMX Mode | █ Stand Alone | Settings | System Info | <table border="1"> <thead> <tr> <th>Stand Alone Mode</th> </tr> </thead> <tbody> <tr> <td>Stop Stand Alone</td> </tr> <tr> <td>Auto FX</td> </tr> <tr> <td>Color Macro</td> </tr> <tr> <td>Quick Color</td> </tr> <tr> <td>Tunable White</td> </tr> <tr> <td>█ User Color</td> </tr> <tr> <td>Color Settings</td> </tr> </tbody> </table> | Stand Alone Mode | Stop Stand Alone | Auto FX | Color Macro | Quick Color | Tunable White | █ User Color | Color Settings | <table border="1"> <thead> <tr> <th>User Color</th> </tr> </thead> <tbody> <tr> <td>Color 1</td> </tr> <tr> <td>Color 2</td> </tr> <tr> <td>Color 3</td> </tr> <tr> <td>Color 4</td> </tr> <tr> <td>Color 5</td> </tr> </tbody> </table> | User Color | Color 1 | Color 2 | Color 3 | Color 4 | Color 5 | <table border="1"> <thead> <tr> <th>User Color</th> </tr> </thead> <tbody> <tr> <td>Dimmer <0-100></td> </tr> <tr> <td>Shutter <0-255></td> </tr> <tr> <td>Red <0-255></td> </tr> <tr> <td>Green <0-255></td> </tr> <tr> <td>Blue <0-255></td> </tr> </tbody> </table> | User Color | Dimmer <0-100> | Shutter <0-255> | Red <0-255> | Green <0-255> | Blue <0-255> |
| Menu | | | | | | | | | | | | | | | | | | | | | | | | | | | | |
| DMX Mode | | | | | | | | | | | | | | | | | | | | | | | | | | | | |
| █ Stand Alone | | | | | | | | | | | | | | | | | | | | | | | | | | | | |
| Settings | | | | | | | | | | | | | | | | | | | | | | | | | | | | |
| System Info | | | | | | | | | | | | | | | | | | | | | | | | | | | | |
| Stand Alone Mode | | | | | | | | | | | | | | | | | | | | | | | | | | | | |
| Stop Stand Alone | | | | | | | | | | | | | | | | | | | | | | | | | | | | |
| Auto FX | | | | | | | | | | | | | | | | | | | | | | | | | | | | |
| Color Macro | | | | | | | | | | | | | | | | | | | | | | | | | | | | |
| Quick Color | | | | | | | | | | | | | | | | | | | | | | | | | | | | |
| Tunable White | | | | | | | | | | | | | | | | | | | | | | | | | | | | |
| █ User Color | | | | | | | | | | | | | | | | | | | | | | | | | | | | |
| Color Settings | | | | | | | | | | | | | | | | | | | | | | | | | | | | |
| User Color | | | | | | | | | | | | | | | | | | | | | | | | | | | | |
| Color 1 | | | | | | | | | | | | | | | | | | | | | | | | | | | | |
| Color 2 | | | | | | | | | | | | | | | | | | | | | | | | | | | | |
| Color 3 | | | | | | | | | | | | | | | | | | | | | | | | | | | | |
| Color 4 | | | | | | | | | | | | | | | | | | | | | | | | | | | | |
| Color 5 | | | | | | | | | | | | | | | | | | | | | | | | | | | | |
| User Color | | | | | | | | | | | | | | | | | | | | | | | | | | | | |
| Dimmer <0-100> | | | | | | | | | | | | | | | | | | | | | | | | | | | | |
| Shutter <0-255> | | | | | | | | | | | | | | | | | | | | | | | | | | | | |
| Red <0-255> | | | | | | | | | | | | | | | | | | | | | | | | | | | | |
| Green <0-255> | | | | | | | | | | | | | | | | | | | | | | | | | | | | |
| Blue <0-255> | | | | | | | | | | | | | | | | | | | | | | | | | | | | |

To define a User Color please press ENTER to access to main menu (level 1).

While using the UP / DOWN arrows, please select the menu item "Stand Alone" and confirm by pressing ENTER.

Select the item menu "User Color" by using the up/down controls and press ENTER.

Using UP and DOWN select your desired preset number (Color 1 -5) and confirm with ENTER.

Use UP and DOWN controls to select your desired color, confirm by ENTER and adjust the value by up and down controls between 000-255 and confirm all entries with ENTER.

With dimmer you can adjust the allover brightness of your User Color. Shutter allows several strobe effects. Once your color mix is ready, jump back by ESC. Your individual color is stored under the selected color preset now.

***Note: All five User Colors are also available by DMX at Color Macro channel.**

For detailed information please see Color Macro Chart at the end of this manual.

Using UP/DOWN arrows at homescreen the Color Macros can be changed according to the list.

Shutter: Please see detailed explanation for strobe effects inside DMX chart at the end of this manual.

Color Settings*

Here at "Color Settings" you can chose your preferred working color mode for all Stand Alone modes. Either Color Calibration or RAW. Chose Color Calibration if the fixture should work accroding to the settings at Color Calibration, either Full Calibration or CCT Calibration, RAW works according to the settings at RAW Balance, either RAW or User Calibrated.

Level 1

| Menu |
|---------------|
| DMX Mode |
| ➤ Stand Alone |
| Settings |
| System Info |

Level 2

| Stand Alone Mode |
|------------------|
| Stop Stand Alone |
| Auto FX |
| Color Macro |
| Quick Color |
| Tunable White |
| User Color |
| ➤ Color Settings |

Level 3

| Color Settings |
|---------------------|
| ➤ Color Calibration |
| RAW |

5.4.5 Settings

Level 1

| Menu |
|-------------|
| DMX Mode |
| Stand Alone |
| ➤ Settings |
| System Info |

| Main Menu | Menu level 2 | Menu level 3 | Menu level 4 | Menu level 5 | Menu level 6 | Remark |
|-------------|----------------------------------------------------------------------------------------------------------------------------------------------------------------------------------------------------------------------------------------------------------------------|----------------------------------------------------------------|-------------------|----------------------------|--------------|--------|
| DMX Mode | <ul style="list-style-type: none"> • 12CH Simple • 27CH Easy • 44CH Standard • 138CH Pure • 269CH Pure Extended • 166CH Full Access • 297CH Full Access Extended • 100CH Pure S2 Merge | | | | | |
| Stand Alone | Stop Stand Alone | | | | | |
| | Auto FX | Stop Program | | | | |
| | | Dimmer <0-100> | | | | |
| | | Speed <0-100> (default 50) | | | | |
| | | Effect 1 | | | | |
| | | Effect 2 | | | | |
| | | Effect 3 | | | | |
| | | Effect 4 | | | | |
| | | Effect 5 | | | | |
| | | Effect 6 | | | | |
| | | Effect 7 | | | | |
| | | Effect 8 | | | | |
| | Effect 9 | | | | | |
| | Effect 10 | | | | | |
| | Color Macro (affects both RGB Panels) | Color Off | | | | |
| | | Dimmer <0-100> | | | | |
| | | Color macros 1-46 (Reference to Stand Alone Color Macro chart) | | | | |
| | Quick Color | Dimmer Single Tubes <0-100> | | affects 2x single CW Tubes | | |
| | | Dimmer RGB Panel <0-100> | | affects RGB Panel | | |
| | | Shutter <0-255> | | affects all | | |
| | Red <0-255> | | affects RGB Panel | | | |
| | Green <0-255> | | affects RGB Panel | | | |
| | Blue <0-255> | | affects RGB Panel | | | |

| Main Menu | Menu level 2 | Menu level 3 | Menu level 4 | Menu level 5 | Menu level 6 | Remark | | |
|-------------|-------------------------------------------------|---------------------------------------------------------------------------------|-----------------------------------------------------------------------------------------------------|--------------|-----------------|----------------------------------------------------------------------------------------------------------------------------------------------------------------------------------------------------------------------------------|------------------------------------------------------------|-----------------------------------------------------------------------------------------|
| Stand Alone | Tunable White (affects RGB Panel) | Dimmer <0-100> | | | | | | |
| | | Shutter <0-255> | | | | | | |
| | | CCT <2000K-10.000K> (default 5600K) | adjustable in 100K steps | | | | | |
| | | Tint <000> +/-127 | 0= no function 001--127 plus green -001 to -127 plus magenta | | | | | |
| | User Color (affects RGB Panel) | Color1 | Dimmer<0-100> | | | | | |
| | | Color2 | Shutter <0-255> | | | | | |
| | | Color3 | Red <0-255> | | | | | |
| | | Color4 | Green <0-255> | | | | | |
| | | Color5 | Blue <0-255> | | | | | |
| | Color Settings (affects Stand Alone Modes only) | Color Calibration | Working according to the settings at Color Calibration, either Full Calibration or CCT Calibration. | | | | | |
| RAW Balance | | Working according to the settings at RAW Balance, either RW or User Calibrated. | | | | | | |
| Settings | Protocol | DMX | | | | enables DMX protocol | | |
| | | Art-Net | | | | enables Art-Net protocol | | |
| | | sACN | | | | enables sACN protocol | | |
| | | Slave | | | | confirm with ENTER, after Slave Mode is activated Display will show Slave Mode. Connect the master and slave units (same model) with a DMX cable and enable one of the stand-alone modes on the master unit (Auto, Quick Color). | | |
| | Ethernet | Art-Net | IP Address | | xxx.xxx.xxx.xxx | | IP address: 1. Set block, confirm, Set 2nd block, confirm | |
| | | sACN | Subnet Mask | | xxx.xxx.xxx.xxx | | Subnet Mask: 1. Set block, confirm, Set 2nd block, confirm | |
| | | | Universe | | | 000-254 | | Sets the Universe |
| | | | Universe Group | | | 000-127 | | Sets the Universe Group |
| | | | Send Current Universe to DMX | | | On / Off | | On: passes current Universe to DMX Out Off: doesn't pass current Universe to DMX Out |
| | | | Send User Universe to DMX | | | On / Off | | On: passes user Universe to DMX Out Off: doesn't pass user Universe to DMX Out |
| | Select Universe | | | 000-254 | | Sets the Universe | | |

| Main Menu | Menu level 2 | Menu level 3 | Menu level 4 | Menu level 5 | Menu level 6 | Remark | |
|-----------|---------------------------------------------------------------|-----------------------------|---------------------------------------------------------------------------------------------------------------------------------------------------------------------------------------------------|--------------|--------------|--------|--|
| Settings | Display | Display Flip <on/off> | On= Flip control panel display by 180° (e.g. for overhead installation) Off= normal control panel display | | | | |
| | | Backlight <on/off> | On= controls permanent on , display itself will deactivate after 60 minutes of inactivity Off= controls and display deactivation after approximately 1 minute of inactivity | | | | |
| | | Auto Lock <on/off> | On= Automatically locks the controls after approximately 1 minute of inactivity. After attempted input the display shows: "Locked!" Unlock process: press arrows up, down, up, down consecutively | | | | |
| | Startup Mode (using last adjustments of Stand-alone Modes) | DMX / Art-Net / sACN | Select your default operating mode when fixture is powered on | | | | |
| | | Auto | | | | | |
| | | Color Macro | | | | | |
| | | Quick Color | | | | | |
| | | Tunable White | | | | | |
| | | User Color (User Color 1-5) | | | | | |
| | DMX Fail | Hold | Hold= last command retains | | | | |
| | | Blackout | Blackout= Activates Blackout | | | | |
| | | Emergency Light | Emergency Light= Fixtures changes to 5600K | | | | |
| | Dimmer Curve | Linear | Linear= Light intensity increases linear with DMX value | | | | |
| | | Exponential | Exponential= Light intensity can be set more smooth at lower DMX values and broadly at higher DMX values. | | | | |
| | | Logarithmic | Light intensity can be broadly adjusted at lower DMX values and more smooth at higher DMX values | | | | |
| | | S-Curve | Light intensity can be adjusted smoothly at lower and higher DMX values and broadly at medium DMX values | | | | |
| | Dimmer Response | LED (Fast) | The LED responds abruptly to DMX value changes at brightness | | | | |
| | | Medium | The LED responds with medium delay to DMX value changes at brightness | | | | |
| | | Halogen (Slow) | The LED responds similar to a halogen fixture with soft changes at brightness. | | | | |

| Main Menu | Menu level 2 | Menu level 3 | Menu level 4 | Menu level 5 | Menu level 6 | Remark | |
|------------------------|---------------------------------------------------------------------|----------------------------|----------------------------------------------------------------------------------------------------------------------------------------------------------------------------------------------------------------|--------------|--------------|--------|-----------------------------------------|
| Settings | Color Calibration (affects Calibrated DMX modes and Stand Alone) | Full Calibration | Calibration on RGB Panel for CCT & Colors | | | | |
| | | CCT Calibration | Calibration on RGB Panel on CCT only, RAW Colors | | | | |
| | RAW Balance (affects DIRECT DMX modes and Stand Alone) | RAW | | | | | R,G,B with maximum value of brightness |
| | | User Calibration | Red | <0-255> | | | individual color calibration of R,G,B |
| | | | Green | <0-255> | | | |
| | Blue | | <0-255> | | | | |
| | LED Frequency | 800 Hz | Select preferred LED PWM frequency | | | | |
| | | 1200 Hz | | | | | |
| | | 2000 Hz | | | | | |
| | | 3600 Hz | | | | | |
| | | 12000 Hz | | | | | |
| | | 25000 Hz | | | | | |
| | Fan | Auto | Adjust fan speed relative to internal fixture temperature | | | | |
| | | Silent | Low fan speed for silent operation | | | | |
| | | Fan Off | Fan Off | | | | |
| | | Max. Power | High fan speed for maximum cooling effect | | | | |
| | Invert / Swap Mapping | RGB Panel | On / Off | | | | Inverts the pixel layout of the fixture |
| | | Single Tube 1 | On / Off | | | | Inverts the pixel layout of the fixture |
| | | Single Tube 2 | On / Off | | | | Inverts the pixel layout of the fixture |
| | | Swap Single Tubes | On / Off | | | | Swaps the Single Tubes of the fixture |
| Transfer Configuration | Including DMX Address | Without DMX Address | Transfer the same menu settings of this fixture to all the other in daisy chain (same model), either with DMX address or without. After power off and on again, the transferred settings should stay the same. | | | | |
| | | | | | | | |

| Main Menu | Menu level 2 | Menu level 3 | Menu level 4 | Menu level 5 | Menu level 6 | Remark | |
|----------------------------------------------------------------------|----------------------|-----------------|--------------------------------------------------------------------------------------------------------------------------------------------|---------------------------------|--------------|--------------------------------------------------------------------------------------------------------------------------------------------------------------------------------------------------------------------------------------------------------------------------------------------------|--|
| Settings | LED Mode | Illumination | Normal output for constant illumination | | | | |
| | | Boost | Boost for temporarily highest output | | | | |
| | USB Update | Yes | Run firmware update via USB port / keeps the current DMX Address | | | | |
| | | No | Do not run firmware update via USB port | | | | |
| | Factory / User Reset | Factory Reset | Are you sure to reset? Confirm by pressing ENTER, cancel with ESC | Select your User Reset defaults | | Note: Factory Reset by Menu sets DMX address back to 1 and DMX mode back to default mode Factory Reset by DMX / RDM keeps current DMX address and DMX mode | |
| | | User Reset | Are you sure to reset? Confirm by pressing ENTER, cancel with ESC | | | Restores all User Reset according to the User Preset List. DMX address restore to Factory default. Once User Reset is activated a fixture self test will start while dimming in and out every single LED and eye and fan. Self Test is not available while activating User Rest by DMX Settings. | |
| | Factory / User Reset | User Reset List | 12CH Simple, 27CH Easy, 44CH Standard, 138CH Pure, 269CH Pure Extended, 166CH Full Access, 297CH Full Access Extended, 100CH Pure S2 Merge | | | | |
| | | | Color Settings < Factory Calibration , RAW> | | | | |
| | | | Protocol < DMX /Art-Net/sACN/ | | | | |
| | | | Display Flip <on/off> | | | | |
| | | | Backlight <on/off> | | | | |
| | | | Auto Lock <on/off> | | | | |
| | | | Startup Mode < DMX , Art-Net, sACN, Auto,Color Macro, Quick Color, Tunable-White, User Color > | Select your User Reset defaults | | | |
| | | | DMX Fail < Hold /Blackout/Emergency> | | | | |
| Dimmer Curve < Linear , Exponential, Logarithmic, S-Curve> | | | | | | | |
| Dimmer Response < LED , Medium, Halogen> | | | | | | | |
| Color Calibration <Full Calibration/ CCT Calibration > | | | | | | | |

| Main Menu | Menu level 2 | Menu level 3 | Menu level 4 | Menu level 5 | Menu level 6 | Remark |
|-----------|----------------------|-----------------|---------------------------------------------------------------------------------|---------------------------------|--------------|--------|
| Settings | Factory / User Reset | User Reset List | RAW Balance <RAW/User Calibrated> | Select your User Reset defaults | | |
| | | | LED Frequency <800Hz, 1200Hz , 2000Hz, 3600Hz, 12000Hz, 25000Hz> | | | |
| | | | Fan < Auto , Silent, Fan Off, Max. Power> | | | |
| | | | Transfer Configuration <including DMX address / without DMX address > | | | |
| | | | LED Mode <Illumination, Boost > | | | |
| | | | USB Update <yes/no> | | | |

5.4.6 System Info

Level 1

| Menu |
|---------------|
| DMX Mode |
| Stand Alone |
| Slave |
| Settings |
| ➤ System Info |

| Main Menu | Menu level 2 | Menu level 3 | Menu level 4 |
|-------------|------------------|---------------------------------------------|------------------------------------------|
| System Info | Firmware Version | vx.xx | Display installed firmware version |
| | Serial Number | 207xxxxxxxx | |
| | RDM UID | 0X6a6ahxxxxxx | Display unique RDM ID for identification |
| | Temperatures | Celsius LED: XXX°C or Fahrenheit LED: XXX°F | LED RGB Panels & Single Tubes |
| | Power on Time | Total: xxxxxhours | Display fixture total power on time |
| | LED on Time | LED RGB Panel & Single Tubes | Total: xxxxxhours |
| | Errors | Errors information | Display error codes |
| | Fan speed | | Displays the current fan speed |

Dimmer Curves

LINEAR



EXPONENTIAL



LOGARITHMIC



S-CURVE



6. ACCESSORIES



Yoke 2.2
Art.: 13907001



Yoke 4.2
Art.: 13907701



Floor Extension
Art.: 13907201



Rigging Bracket G2
Art.: 13907411



Floor Bracket
Art.: 13908501



Vertical Bracket
Art.: 13908401



Omega Bracket ST
Art.: 90900002



Cases
tba



FX Filterframe SC
Art.: 13908801



FX Filterframe EH
Art.: 13908601



FX Filterframe EV
Art.: 13908701



FX Distance Frame
Art.: 13908901

7. TECHNICAL DATA / DIAGRAMS

7.1 Technical drawings and measurements

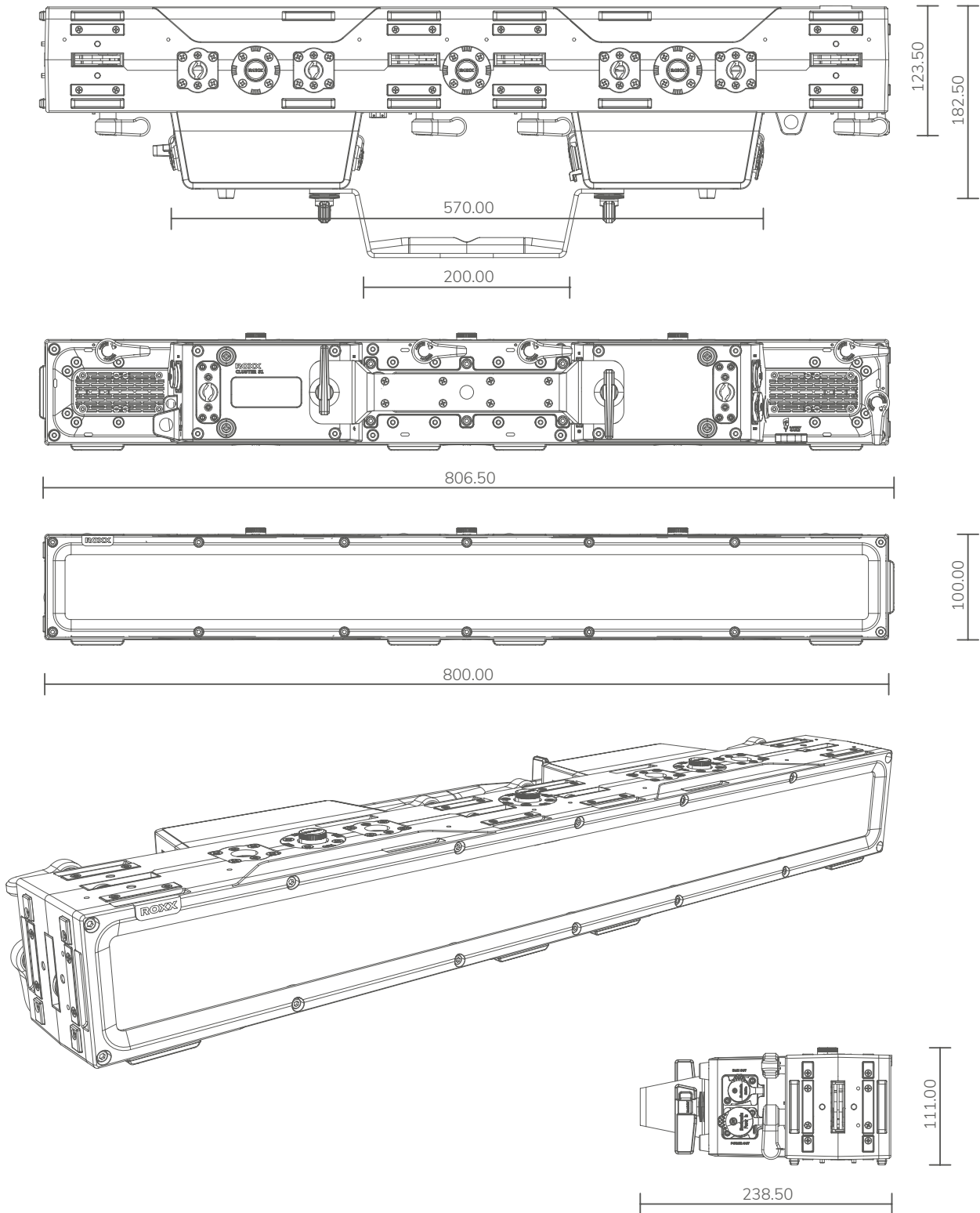

7.2 IP Rating

ROXX products conform to officially classified IP standard levels. CLUSTER S1 is rated to IP65 when using the covers for the housing parts. IP stands for Ingress Protection and IP65, according to classified standard, means shielded against dust and high-pressure jets of water from any side.

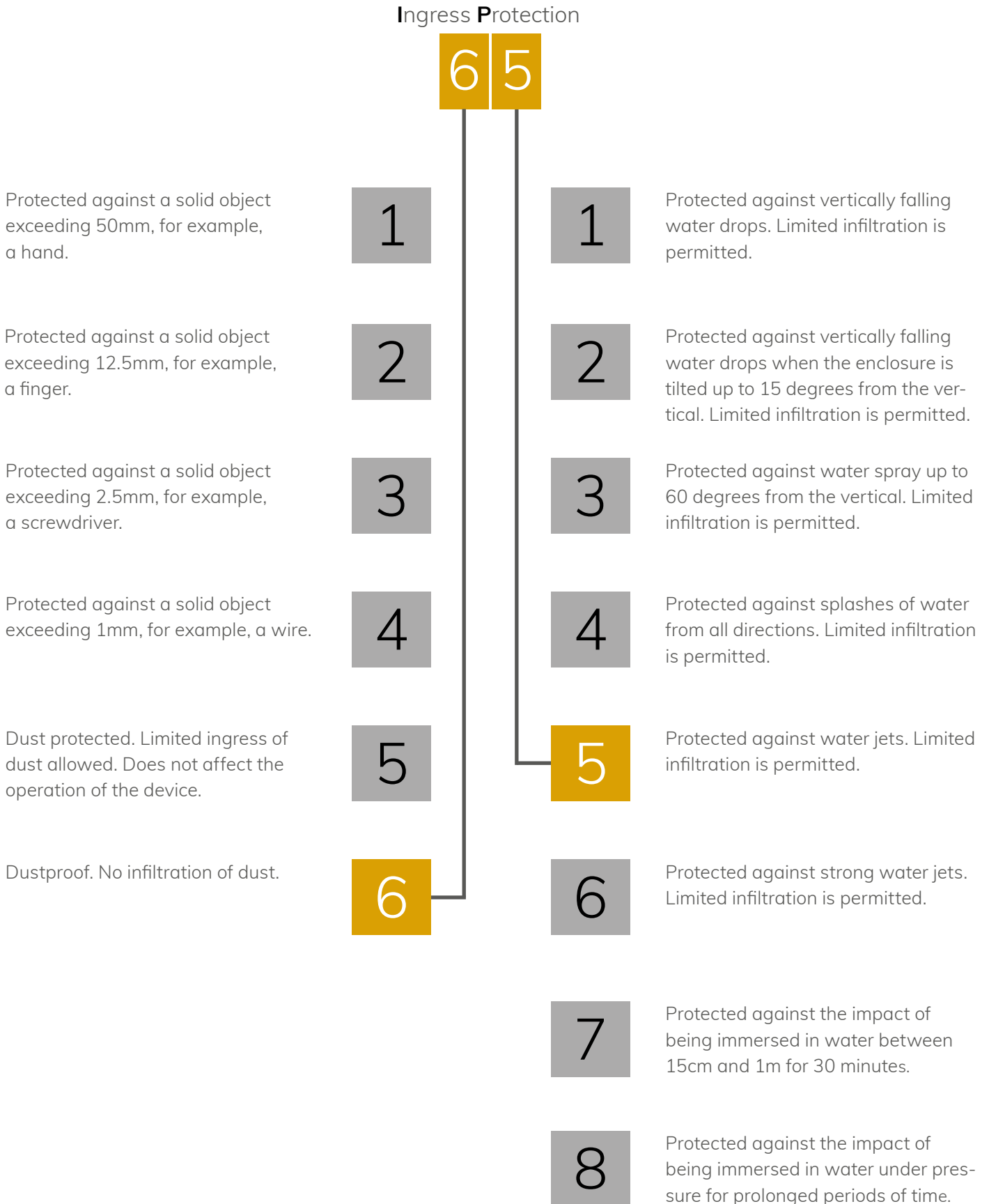

7.3 Technical Data

| Photometrics | |
|------------------------------------------------------------------|------------------------------------------------------------------------------------------------------------------------------------------------------|
| LED expected lifetime | 50.000 hours |
| Lightsource | 288 x CW LED's (7000K), 720 x RGB LED's |
| Type of optical system | native, elliptical lens |
| LED PWM Frequency | selectable 800Hz, 1.200Hz, 2.000Hz, 3.600Hz, 12kHz, 25kHz |
| Beam angles @ Full (50%) | 66° |
| Maximum Field angles @ Full (10%) | 108° |
| Color temperature range | 2000-10.000K |
| CRI/Ra @ Full | tba |
| Efficacy @ Full (max) | tba |
| Luminous flux @ Full | tba |
| Luminous flux @ 2x Single Strobes (Boost Mode) | tba |
| Luminous flux @ RGB Panel (Boost Mode) | tba |
| Luminous flux @ 2x Single Strobes (Illumination Mode) | tba |
| Luminous flux @ 2x RGB Panel (Illumination Mode) | tba |
| illuminance Lux @ 3m / 9,84ft (@ Full/ Boost Mode) | tba |
| illuminance Lux @ 3m / 9,84ft (@ 2x Single Strobes / Boost Mode) | tba |
| illuminance Lux @ 3m / 9,84ft (@ RGB Panel) | tba |
| Thermal Characteristics | |
| Cooling | Active, Forced Air, Temperature-regulated |
| Humidity (max.) | 95% |
| Temperature range, Operating | -40°C to 45°C |
| Temperature range, Start-Up | -20° to 45°C |
| Temperature range, Storage | -40°C to 80°C |
| Thermal Protection | Automatic overtemperature protection |
| Electrical Data | |
| AC Power, max | 90 – 285V 50/60Hz |
| AC Power, nominal | 100 – 240V 50/60Hz |
| Electrical protection | Overload protection with automatic recover |
| Max. power consumption (Boost Mode) | 1010W |
| Constant power consumption (Illumination Mode) | 215W |
| Power Max. Out @ Max. Power Consumption | 3,97A @ 230V (910W) / 11,3A @ 100V (970W) |
| Power Max. Out @ Constant Power Consumption | 0,99A @ 230V (215W) / 2,24A @ 100V (220W) |
| Power Linking @ Max. Power Consumption (Boost Mode) | 3 units @ 230V / 0 unit @ 100V |
| Power Linking @ Constant Power Consumption (Illumination Mode) | 11 units @ 230V / 4 units @ 100V |
| Power Factor @ Max. Power Consumption (Boost Mode) | 0.88PF @ 100V / 1,00PF @ 230V |
| Power Factor @ Constant Power Consumption (Illumination Mode) | 0,985PF @ 100V / 0,981 PF @ 230V |
| Power Supply Unit | Inbuilt auto-ranging electronic switch-mode |
| Operator & Controller | |
| DMX channels | 12CH Simple, 27CH Easy, 44CH Standard, 138CH Pure, 269CH Pure Extended Mode, 166CH Full Access, 297CH Full Access Extended, 100CH Pure S2 Merge Mode |
| DMX modes | 8 |
| Protocol | USITT DMX512A, RDM ANSI E1.20 Art-Net, sACN |

7.3 Technical Data

| | |
|------------------------------------------------------------|----------------------------------------------------------------------------------------------------------------------------------------------------------------------------------------------------------------|
| Setting and addressing | OLED graphical display / 4 controls RDM ANSI E1.20 |
| Standalone mode | Auto Program, Color Macro, Quick Color, Tunable White, User Color |
| Wireless DMX | n.a. |
| Indicator | OLED graphical display |
| Controls | 4 touch sensitive, backlighted controls |
| Strobe | 0-30Hz |
| DMX I/O | IP65 XLR 5-pin male/female |
| Ethernet I/O | IP65 RJ45 Ethernet male/female |
| Power In | TRUE1 compatible input & link-thru sockets |
| USB Firmware Update | IP65 USB socket |
| Dimensions & Weight | |
| IP class | IP65 |
| IK class | IK06 |
| Body material | Aluminum, Nylon |
| Lens material | Tempered glass front |
| Net dimensions without Yoke (w x h x d) | 800 x 100 x 182,5mm |
| Net dimensions inches | 31,49 x 3,93 x 7,19 inches |
| Net weight | 12,84kg / 28,31lbs |
| Tilt | 288° |
| Tilt Locking System | Yoke positions included (optional Yoke) |
| Included / Optional | |
| Included items | 2x Puk, 2m Power Cable |
| Optional Accessories | FX Filter Vertical, FX Filter Horizontal, FX Filter Smoked Clear, FX Distance Frame, Yoke 2.2, Yoke 4.2, Yoke 4.3, Yoke Floor Extension, Floor Bracket, Vertical Bracket, Rigging Bracket G2, Omega Bracket ST |
| Color options | Black – RAL 9004 (Standard) Custom color – any RAL (on request) |
| Installation | |
| Mounting point on fixture top & rear side | 2x 1/4 turn Omega Bracket |
| Mounting point with optional Rigging Bracket G2 | 2x/4x 13mm or 1/2" holes for Clamp fixation |
| Mounting point by optional Yokes (vertical mount) | 1x/3x 13mm or 1/2" holes, 1x centric TV Spigot attachment, 1x/3x integrated Camlocks for Omega Brackets |
| Mounting point by vertical bracket on fixtures header side | 1x13mm / 1/2" hole, 1x 1/4 turn Omega Bracket |
| Orientation | Any |
| Rigging possibilities | direct or due optional rigging accessories |
| Safety features | 2x rear mounts for fixture & accessory safety wire |
| Minimum distance from flammable materials | 0,3 meters (11,8 inch) |

7.4 DMX-Charts / Color Macro Charts / CCT Chart

| |
|--------------------------------------|
| 12CH Easy Mode |
| 27CH Easy Mode |
| 44CH Standard Mode (default) |
| 138CH Pure Mode |
| 269CH Pure Extend Mode |
| 166CH Full Access Mode |
| 297CH Full Access Extend Mode |
| 100CH S2 Pure Mode |

Here you can find the DMX charts and Pattern Charts for the Cluster S1 for reading or downloading. Simply click on the icon or scan the QR code.

DMX charts

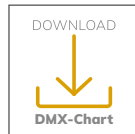

Pattern charts

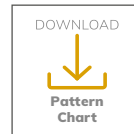

Pixel charts

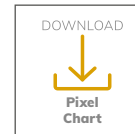

| Gels - Color Macros for DMX | | |
|-----------------------------|-------------------|----------------|
| DMX value | Gel Name | Color Number |
| 000-005 | no function | |
| 006-008 | Red | 100% Red LED |
| 009-011 | Fire | LEE 019 |
| 012-014 | Medium Red | LEE 027 |
| 015-017 | Primary Red | LEE 106 |
| 018-020 | Med Amber | LEE 020 |
| 021-023 | Dark Amber | LEE 022 |
| 024-026 | Deep Amber | LEE 104 |
| 027-029 | Orange | LEE 105 |
| 030-032 | Deep Golden Amber | LEE 135 |
| 033-035 | Yellow | LEE 101 |
| 036-038 | Green | 100% Green LED |
| 039-041 | Lime Green | LEE 088 |
| 042-044 | Moss Green | LEE 089 |
| 045-047 | LEE Green | LEE 121 |
| 048-050 | Primary Green | LEE 139 |
| 051-053 | Jas Green | LEE 738 |
| 054-056 | Jade | LEE 323 |
| 057-059 | Blue | 100% Blue LED |
| 060-062 | Sky Blue | LEE 068 |
| 063-065 | Tokyo Blue | LEE 071 |
| 066-068 | Light Blue | LEE 118 |
| 069-071 | Marine Blue | LEE 131 |
| 072-074 | Med Blue | LEE 132 |
| 075-077 | Congo Blue | LEE 181 |
| 078-080 | Mikkel Blue | LEE 716 |
| 081-083 | Rose Pink | LEE 002 |
| 084-086 | Med Pink | LEE 036 |
| 087-089 | Light Lavender | LEE 052 |
| 090-092 | Lavender | LEE 058 |

| Gels - Color Macros for DMX | | |
|-----------------------------|---------------------------------|----------------|
| 093-095 | Magenta | LEE 113 |
| 096-098 | Mauve | LEE 126 |
| 099-101 | Smokey Pink | LEE 127 |
| 102-104 | Special Med Lavender | LEE 343 |
| 105-107 | Ultimate Violet | LEE 707 |
| 108-110 | Magical Magenta | LEE 795 |
| 111-113 | Chrysalis Pink | LEE 798 |
| 114-116 | Specia KH Lavender | LEE 799 |
| 117-119 | Bulb White | 2700K |
| 120-122 | Halogen White | 3200K |
| 123-125 | Neutral White | 4200K |
| 126-128 | Daylight White | 5600K |
| 129-131 | Cold White I | 6000K |
| 132-134 | Cold White II | 6300K |
| 135-137 | White (only if available) | 100% White LED |
| 138-140 | Amber (only if available) | 100% Amber LED |
| 141-143 | Lime (only if available) | 100% Lime LED |
| 144-146 | Cyan (only if available) | 100% Cyan LED |
| 147-149 | User Color 1 | |
| 150-152 | User Color 2 | |
| 153-155 | User Color 3 | |
| 156-158 | User Color 4 | |
| 159-161 | User Color 5 | |
| 162-164 | Color Jumping stop | |
| 165-209 | Color Jumping speed slow @ fast | color 1-37 |
| 210-255 | Color fading speed slow @ fast | color 1-37 |

Color Macro Chart for Stand Alone

| Gels - Color Macros for Standalone Mode | | |
|-----------------------------------------|-------------------|----------------|
| Position | Gel Name | Color Number |
| 1 | Red | 100% Red LED |
| 2 | Fire | LEE 019 |
| 3 | Medium Red | LEE 027 |
| 4 | Primary Red | LEE 106 |
| 5 | Med Amber | LEE 020 |
| 6 | Dark Amber | LEE 022 |
| 7 | Deep Amber | LEE 104 |
| 8 | Orange | LEE 105 |
| 9 | Deep Golden Amber | LEE 135 |
| 10 | Yellow | LEE 101 |
| 11 | Green | 100% Green LED |
| 12 | Lime Green | LEE 088 |
| 13 | Moss Green | LEE 089 |
| 14 | LEE Green | LEE 121 |
| 15 | Primary Green | LEE 139 |
| 16 | Jas Green | LEE 738 |
| 17 | Jade | LEE 323 |
| 18 | Blue | 100% Blue LED |
| 19 | Sky Blue | LEE 068 |
| 20 | Tokyo Blue | LEE 071 |
| 21 | Light Blue | LEE 118 |
| 22 | Marine Blue | LEE 131 |
| 23 | Med Blue | LEE 132 |
| 24 | Congo Blue | LEE 181 |
| 25 | Mikkel Blue | LEE 716 |
| 26 | Rose Pink | LEE 002 |
| 27 | Med Pink | LEE 036 |
| 28 | Light Lavender | LEE 052 |

| Gels - Color Macros for Standalone Mode | | |
|-----------------------------------------|---------------------------|----------------|
| Position | Gel Name | Color Number |
| 29 | Lavender | LEE 058 |
| 30 | Magenta | LEE 113 |
| 31 | Mauve | LEE 126 |
| 32 | Smokey Pink | LEE 127 |
| 33 | Special Med Lavender | LEE 343 |
| 34 | Ultimate Violet | LEE 707 |
| 35 | Magical Magenta | LEE 795 |
| 36 | Chrysalis Pink | LEE 798 |
| 37 | Specia KH Lavender | LEE 799 |
| 38 | Bulb White | 2700K |
| 39 | Halogen White | 3200K |
| 40 | Neutral White | 4200K |
| 41 | Daylight White | 5600K |
| 42 | Cold White I | 6000K |
| 43 | Cold White II | 6300K |
| 44 | Amber (only if available) | 100% Amber LED |
| 45 | Lime (only if available) | 100% Lime LED |
| 46 | Cyan (only if available) | 100% Cyan LED |

CTC channel
DMX / Color temperature

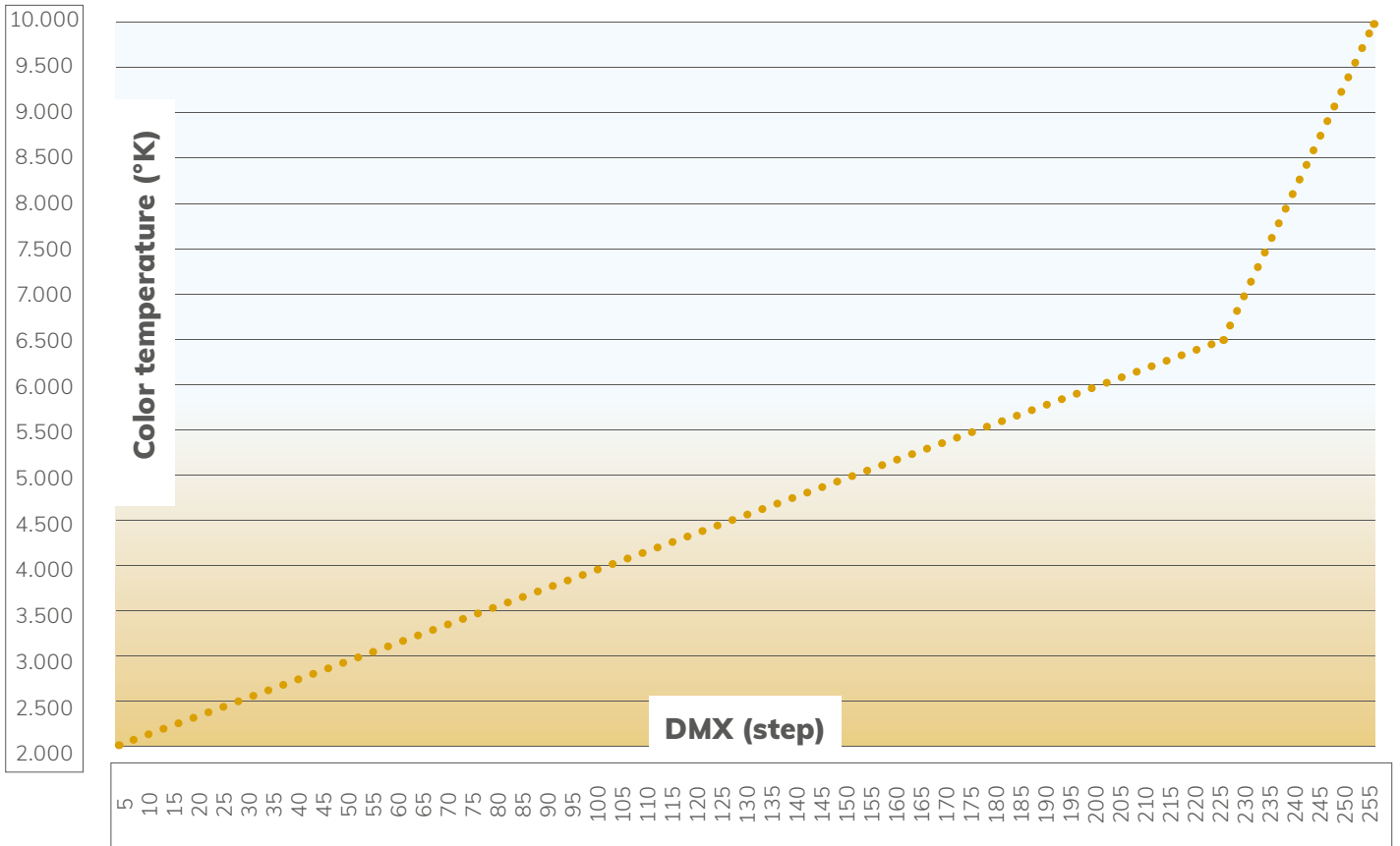

CTC-Chart

| DMX (Step) | Color Temp (°K) | DMX (Step) | Color Temp (°K) | DMX (Step) | Color Temp (°K) | DMX (Step) | Color Temp (°K) | DMX (Step) | Color Temp (°K) | DMX (Step) | Color Temp (°K) |
|------------|-----------------|------------|-----------------|------------|-----------------|------------|-----------------|------------|-----------------|------------|-----------------|
| 0 | 7000 | 43 | 2774 | 86 | 3649 | 129 | 4525 | 172 | 5400 | 215 | 6276 |
| 1 | 7000 | 44 | 2794 | 87 | 3670 | 130 | 4545 | 173 | 5421 | 216 | 6296 |
| 2 | 7000 | 45 | 2814 | 88 | 3690 | 131 | 4566 | 174 | 5441 | 217 | 6317 |
| 3 | 7000 | 46 | 2835 | 89 | 3710 | 132 | 4586 | 175 | 5462 | 218 | 6337 |
| 4 | 7000 | 47 | 2855 | 90 | 3731 | 133 | 4606 | 176 | 5482 | 219 | 6357 |
| 5 | 2000 | 48 | 2876 | 91 | 3751 | 134 | 4627 | 177 | 5502 | 220 | 6378 |
| 6 | 2020 | 49 | 2896 | 92 | 3771 | 135 | 4647 | 178 | 5523 | 221 | 6398 |
| 7 | 2041 | 50 | 2916 | 93 | 3792 | 136 | 4667 | 179 | 5543 | 222 | 6419 |
| 8 | 2061 | 51 | 2937 | 94 | 3812 | 137 | 4688 | 180 | 5563 | 223 | 6439 |
| 9 | 2081 | 52 | 2957 | 95 | 3833 | 138 | 4708 | 181 | 5584 | 224 | 6459 |
| 10 | 2102 | 53 | 2977 | 96 | 3853 | 139 | 4729 | 182 | 5604 | 225 | 6480 |
| 11 | 2122 | 54 | 2998 | 97 | 3873 | 140 | 4749 | 183 | 5624 | 226 | 6500 |
| 12 | 2143 | 55 | 3018 | 98 | 3894 | 141 | 4769 | 184 | 5645 | 227 | 6621 |
| 13 | 2163 | 56 | 3038 | 99 | 3914 | 142 | 4790 | 185 | 5665 | 228 | 6741 |
| 14 | 2183 | 57 | 3059 | 100 | 3934 | 143 | 4810 | 186 | 5686 | 229 | 6862 |
| 15 | 2204 | 58 | 3079 | 101 | 3955 | 144 | 4830 | 187 | 5706 | 230 | 6983 |
| 16 | 2224 | 59 | 3100 | 102 | 3975 | 145 | 4851 | 188 | 5726 | 231 | 7103 |
| 17 | 2244 | 60 | 3120 | 103 | 3995 | 146 | 4871 | 189 | 5747 | 232 | 7224 |
| 18 | 2265 | 61 | 3140 | 104 | 4016 | 147 | 4891 | 190 | 5767 | 233 | 7345 |
| 19 | 2285 | 62 | 3161 | 105 | 4036 | 148 | 4912 | 191 | 5787 | 234 | 7466 |
| 20 | 2305 | 63 | 3181 | 106 | 4057 | 149 | 4932 | 192 | 5808 | 235 | 7586 |
| 21 | 2326 | 64 | 3201 | 107 | 4077 | 150 | 4952 | 193 | 5828 | 236 | 7707 |
| 22 | 2346 | 65 | 3222 | 108 | 4097 | 151 | 4973 | 194 | 5848 | 237 | 7828 |
| 23 | 2367 | 66 | 3242 | 109 | 4118 | 152 | 4993 | 195 | 5869 | 238 | 7948 |
| 24 | 2387 | 67 | 3262 | 110 | 4138 | 153 | 5014 | 196 | 5889 | 239 | 8069 |
| 25 | 2407 | 68 | 3283 | 111 | 4158 | 154 | 5034 | 197 | 5910 | 240 | 8190 |
| 26 | 2428 | 69 | 3303 | 112 | 4179 | 155 | 5054 | 198 | 5930 | 241 | 8310 |
| 27 | 2448 | 70 | 3324 | 113 | 4199 | 156 | 5075 | 199 | 5950 | 242 | 8431 |
| 28 | 2468 | 71 | 3344 | 114 | 4219 | 157 | 5095 | 200 | 5971 | 243 | 8552 |
| 29 | 2489 | 72 | 3364 | 115 | 4240 | 158 | 5115 | 201 | 5991 | 244 | 8672 |
| 30 | 2509 | 73 | 3385 | 116 | 4260 | 159 | 5136 | 202 | 6011 | 245 | 8793 |
| 31 | 2529 | 74 | 3405 | 117 | 4281 | 160 | 5156 | 203 | 6032 | 246 | 8914 |
| 32 | 2550 | 75 | 3425 | 118 | 4301 | 161 | 5176 | 204 | 6052 | 247 | 9034 |
| 33 | 2570 | 76 | 3446 | 119 | 4301 | 162 | 5197 | 205 | 6072 | 248 | 9155 |
| 34 | 2590 | 77 | 3466 | 120 | 4342 | 163 | 5217 | 206 | 6093 | 249 | 9276 |
| 35 | 2611 | 78 | 3486 | 121 | 4362 | 164 | 5238 | 207 | 6113 | 250 | 9397 |
| 36 | 2631 | 79 | 3507 | 122 | 4382 | 165 | 5258 | 208 | 6133 | 251 | 9517 |
| 37 | 2652 | 80 | 3527 | 123 | 4403 | 166 | 5278 | 209 | 6154 | 252 | 9638 |
| 38 | 2672 | 81 | 3548 | 124 | 4423 | 167 | 5299 | 210 | 6174 | 253 | 9759 |
| 39 | 2692 | 82 | 3568 | 125 | 4443 | 168 | 5319 | 211 | 6195 | 254 | 9879 |
| 40 | 2713 | 83 | 3588 | 126 | 4464 | 169 | 5339 | 212 | 6215 | 255 | 10000 |
| 41 | 2733 | 84 | 3609 | 127 | 4484 | 170 | 5360 | 213 | 6235 | | |
| 42 | 2753 | 85 | 3629 | 128 | 4505 | 171 | 5380 | 214 | 6256 | | |

7.5 RDM Templates*

The ROXX Show series features support for various RDM functions.

RDM (Remote Device Management) is a protocol enhancement to USITT DMX512 that allows bi-directional communication between the fixtures and the controller over a standard DMX line. This protocol will allow configuration, status monitoring and management.

You will need a RDM controller to get control over the supported parameters. See the tables below for supported RDM features.

| | |
|---------------|-----------------|
| Label: | ROXX CLUSTER S1 |
| Model: | CLUSTER S1 |
| Manufacturer: | ROXX |
| ID: | 6A6Ah |
| Device ID: | 207 xxxx |

ⓘ *Note: During RDM identifying process CLUSTER S1 flashes white to blue color alternately.

RDM functions

For easy identifying ROXX CLUSTER S1 during RDM process the unit will jump from white color to blue color every second.

| PID | Function | Action | Values |
|--------|---------------------------|--------|--------------------------------------------------------------------------------------|
| 0x00F0 | DMX Start Adress | Set | 001-512 |
| 0x00E0 | DMX Personality | Set | 8 x DMX Modes |
| 0x00E1 | DMX Slots | Read | n.a. |
| 0x0500 | Display Flip | Set | 0= On / 1= Off |
| 0x8051 | Display Backlight | Set | 0= Off / 1= On |
| 0x8052 | Display Lock | Set | 0= Off / 1= On |
| 0x8001 | Effect | Set | tba |
| 0x8002 | Effect Dimmer | Set | 0-100 |
| 0x8003 | Effect Speed | Set | 0-100 |
| 0x8062 | Protocol | Set | tba |
| 0x8053 | Startup Mode | Set | 0= DMX / 1= AUTO / 2= Color Macro / 3= Quick Color / 4= Tunable White / 5=User Color |
| 0x8060 | Color Settings | Set | 0= Color Calibration / 1= RAW |
| 0x8054 | DMX Fail | Set | 1= Hold / 2= Blackout / 3= Emergency |
| 0x8055 | Dimmer Curve | Set | 1= Linear / 2= Exponential / 3= Logarithmic / 4= S-Curve |
| 0x8056 | Dimmer Response | Set | 1= LED / 2= Medium / 3= Halogen |
| 0x8061 | Color Calibration | Set | 0=CCT Calibration / 1= Full Calibration |
| 0x8058 | RAW Balance | Set | 0= RAW / 1= User Calibration |
| 0x8101 | User Calibration - Red | Set | 0-255 |
| 0x8102 | User Calibration - Green | Set | 0-255 |
| 0x8103 | User Calibration - Blue | Set | 0-255 |
| 0x8059 | LED Frequency (PWM) | Set | 1= 800Hz / 2= 1200Hz / 3= 2000Hz / 4= 3600Hz / 5= 12kHz / 6=25kHz |
| 0x805A | Fan | Set | 0= Auto / 1= Silent / 2= Fan Off / 3= Max. Power |
| 0x8063 | Invert Mapping RGB Panel1 | Set | 0= Off / 1= On |

| PID | Function | Action | Values |
|--------|-------------------------------------------|--------|----------------------------|
| 0x8066 | Invert Mapping Single Tube 1 | Set | 0= Off / 1= On |
| 0x8067 | Invert Mapping Single Tube 2 | Set | 0= Off / 1= On |
| 0x806B | Invert Mapping Swap Single Tubes | Set | 0= Off / 1= On |
| 0x805C | LED Mode | Set | 0= Illumination / 1= Boost |
| 0x805E | Factory Reset | Set | 0= No / 1= Yes |
| 0x805F | User Reset | Set | 0= No / 1= Yes |
| 0x00C0 | Firmware Version | Read | n.a. |
| 0x8700 | Serial Number | Read | n.a. |
| 0x0400 | Device Power on Time | Read | n.a. |
| 0x8701 | Temperature LED RGB Panels & Single Tubes | Read | n.a. |
| 0x8702 | Temperature LED Centric Tube | Read | n.a. |
| 0x8705 | LED on Time RGB Panels | Read | n.a. |
| 0x8706 | LED on Time Centric Tube | Read | n.a. |
| 0x8707 | LED on Time Single Tubes | Read | n.a. |
| 0x8709 | Fan Speed | Read | n.a. |

Sensors

RDM enables various readouts for remote device monitoring. See the table below for sensors and sensor types. Please note: The RDM controller communicates with the fixtures to show only the available sensors for this fixture. The table is subject to change without notice.

| Name | |
|------------------|--------------|
| Temperature | xx°C / xxx°F |
| Software Version | SW-Version |
| Errors | |

7.6 Firmware Updating

Here you can find the Firmware Update Instructions for reading or downloading. Simply click on the icon or scan the QR code.



8. TROUBLESHOOTING

Did you try turning the device off and on again?

| Problem | Reason | Solution |
|--------------------------------|----------------------------------------|----------------------------------------------------------------|
| Device is not responding. | No power. | Check cable connections and conform that power is switched on. |
| | Fuse defect. | Contact your qualified service technician / manufacturer. |
| Device has turned off. | Power failure or power was turned off. | Check power supply, fuse, connections, switches. |
| Device has stopped responding. | DMX cable correct? | Check cables. |
| Device operates strangely. | DMX cable inverted (pins correct?) | Use a phase inverter or different cables. |
| | DMX cable terminated? | If not, install DMX termination at the end of the cable. |
| | Stand Alone program running? | Stop internal Stand Alone. |

9. MANUFACTURER'S DECLARATION

Manufacturer's Warranty & Limitations of Liability

Please find our warranty conditions and limitations of liability inside our manufacturer's declaration at www.roxxlight.com/support

Requesting Warranty-Service

To request warranty service for your product, please contact:

ROXX GmbH,
Hansestr. 91
51149 Köln

Email: info@roxxlight.com or the ROXX authorized reseller in your country, from where you purchased your product.

Correct Disposal of this product



This is for the European Union and European countries with electrical waste collection systems. When this label is shown on the product or brochure it means that the item cannot be disposed with household waste. In order to prevent damage to the environment or human health please do not dispose this product uncontrolled. Make sure to act responsible, recycle this product separately from other types of waste to enable lasting reuse of resources. Private users please contact the retailer where you purchased this product or your local authorities to find out where and how proper recycling of this item is possible. Business users please contact your supplier or check the terms and conditions of your purchasing contract. Make sure not to mix this product with other commercial waste.

FCC Statement

This device complies with Part 15 of the FCC Rules. Operation is subject to the following two conditions:

- (1) This device may not cause harmful interference, and
- (2) This device must accept any interference received, including interference that may cause undesired operation

NOTE: This equipment has been tested and found to comply with the limits for a Class B digital device, pursuant to Part 15 of the FCC Rules. These limits are designed to provide reasonable protection against harmful interference in a residential installation. This equipment generates, uses and can radiate radio frequency energy and, if not installed and used in accordance with the instructions, may cause harmful interference to radio communications. However, there is no guarantee that interference will not occur in a particular installation. If this equipment does cause harmful interference to radio or television reception, which can be determined by turning the equipment off and on, the user is encouraged to try to correct the interference by one or more of the following measures:

- Reorient or relocate the receiving antenna.
- Increase the separation between the equipment and receiver.
- Connect the equipment into an outlet on a circuit different from that to which the receiver is connected.
- Consult the dealer or an experienced radio/TV technician for help.

CE Compliance

The equipment marketed by ROXX GmbH complies (where applicable) with the essential requirements and other specifications of the following Directives:

- 2014/30/EU (EMC)
- 2014/35/EU (LVD)
- 2011/65/EU (RoHS)

The complete EU- and UK-Declaration of Conformity can be found at www.roxxlight.com/support, or you can also request it at info@roxxlight.com



QR code tauschen

