

# CLUSTER **B2 FC**



USER MANUAL

## CONTENT

### 1. Safety Informations

1.1. General Preventive Measures	4
1.2. Regulations for equipment that connects to power mains	5
1.3. Technical warnsigns and explanation	6

### 2. Introduction

2.1. About us	7
2.2. CLUSTER B2 FC	7

### 3. General Product Information

3.1. Scope of delivery	8
3.2. Control Functions	8
3.3. Features	8

### 4. Installation & Setup

4.1 Physical Installation and Rigging	9
4.2 Connections	14
4.2.1. AC Power	15
4.2.2. DMX Connection	15
4.2.2.1. Cable Connection	15

### 5. Operation

5.1 Start up	16
5.2 Control Display	16
5.3 Display Short Cuts	16
5.4 Configuration	17
5.4.1 Set DMX Start Address (Direct Access)	17
5.4.2 Selecting DMX Mode	18
5.4.3 Stand Alone	19
5.4.4 Slave Mode	24
5.4.5 Settings	24
5.4.6 System Info	27

### 6. Accessories

6.1 Accessories	28
-----------------	----

---

## **7. Technical Data / Diagrams**

---

7.1 Technical drawings and measurements	29
7.2 IP Rating	30
7.3 Technical Data	31
7.4 DMX-Charts / Color Macro Charts / CCT Chart	33
7.5 RDM Templates	78

---

## **8. Troubleshooting**

---

80

## **9. Manufacturer's Declaration**

---

81

## 1. SAFETY INFORMATION

### 1.1. General Preventive Measures

- 1.1.1. Please read, understand and follow the instructions.
- 1.1.2. Store the instructions and information in a safe place.  
Best solution is the ring binder provided by ROXX.
- 1.1.3. Follow all safety warnings. Under no circumstances remove safety warnings or other information from the equipment.
- 1.1.4. Don't use the equipment for any other intended purpose or manner.
- 1.1.5. Use only stable and compatible stands and/or brackets. Especially when fix installed.  
Make sure the wall brackets are properly installed and safe. Make sure the device is securely installed and cannot fall.
- 1.1.6. Check the safety regulations applying for your country before and during installation.
- 1.1.7. Keep the device away from heat! Don't place/install near heaters, ovens or any source of heat.  
Make sure that the device always is efficiently cooled and cannot overheat.
- 1.1.8. Always guarantee that ventilation and cooling slots are clean and not blocked.
- 1.1.9. Item must be away minimum 20cm from anything around and above it.
- 1.1.10. Do not use this device close to water.
- 1.1.11. Do not expose this equipment to flammable materials.
- 1.1.12. Make sure that no objects can fall into the device.
- 1.1.13. Only use this device with the accessories recommended by the manufacturer.
- 1.1.14. Always check the equipment for housing damages, so that no water can enter the device.  
No containers containing liquids of any kind should be place on top of the unit.
- 1.1.15. Opening or modifying this device is only allowed by authorized and qualified persons.
- 1.1.16. All cables need to be checked after connecting the device in order to prevent damage or accidents.
- 1.1.17. Make sure that the device is transported safe and packed proper in order to prevent damage of any kind.
- 1.1.18. Once you notice improper function of your device due to damage, electric shock or anything similar,  
immediately unplug the unit from the mains outlet and contact our service department.
- 1.1.19. Clean the device with a dry cloth.

- 1.1.20. Observe all disposal laws applicable in your country. Especially for the packaging.
- 1.1.21. Plastic bags are not a toy! Keep away from children!
- 1.1.22. Please note that changes or modifications which are not approved by the party responsible for compliance will void the user's authority to operate the device.

## **1.2 Regulations for equipment that connects to power mains**

- 1.2.1. If an earthing contact is available in the used power cord, it must be used in combination with a power outlet, providing a protective ground. In no circumstances should the protective ground be deactivated.
- 1.2.2. Do not switch on the device immediately after it has been in strong different temperatures, especially after transport. Let the device acclimatize to the temperature in the room of usage first to prevent moisture and condensation.
- 1.2.3. Verify that the correct voltage and frequency are available in the area of operation, before connecting the unit to the mains outlet.
- 1.2.4. If the plug doesn't fit in your mains outlet, contact your electrician.
- 1.2.5. Make sure your power cord/adaptor/connector does not show signs of kinks/warps or is being stepped on.
- 1.2.6. Always disconnect the unit when not in use or being cleaned. Don't pull on the cord to disconnect. Only touch power connections with dry hands!
- 1.2.7. Don't switch the unit on/off rapidly. This may cause damage.
- 1.2.8. If a fuse needs to be replaced, ALWAYS make sure that exactly the same fuse will be used (type and rating). Repeatedly blown fuses need to be checked by an authorised service technician.
- 1.2.9. In the risk of lightning strike all units need to be unplugged from the mains in order to prevent damage.
- 1.2.10. During installation there must be a voltage free condition.
- 1.2.11. The device needs to be cleaned and serviced regularly and will credit this with a longer life cycle. Dust, dirt, moist, water, smoke, nicotine or anything similar inside the unit will cause damage/malfunction.
- 1.2.12. The unit needs to have at least 0,5m distance to anything flammable.
- 1.2.13. You have to make sure that any electrical installation applies to the laws of your country. Correct power cables and applying standards have to be used.

### 1.3. Technical warnsigns and explanation



In order to prevent the risk of an electric shock, under no circumstances remove the cover/back or open the unit in any way! No user serviceable parts are inside. Service, maintenance and repairs should only be done by qualified service personnel or the manufacturer.



Dangerous uninsulated voltage inside the device can cause an electrical shock when opened by unqualified personnel.



Important operating and maintenance instructions apply!



Do not operate this device in tropical climates.



CAUTION! Intense LED light source! Risk of eye damage. Do not look into the light source



The housing surface of the spotlight can heat up to temperatures as high as 70 °C in regular use. Ensure that it is not possible to come into contact with the housing unintentionally. Always allow sufficient time for the lamp to cool down before dismantling, carrying out maintenance work or charging etc..



#### IMPORTANT INFORMATION!

- This is a product which has been developed for professional usage in event technology. It is not suitable as a household lighting.
- NEVER stare, not even temporarily, directly into the light source.
- Don't use magnifiers or any other optical instrument to look at the beam.
- The effects of this device, especially the stroboscope effect, can cause problems for sensitive people or may even cause epileptical seizures.

## 2. INTRODUCTION

### 2.1. About us

*The name ROXX® came easily.*

Combined with the concentrated knowledge and many years of experience, our three founders, who have been leaving their mark in the event and lighting industry for many years already, came together in 2020 to start this outstanding venture.

Product development, sales and marketing as well as the exceptional know-how and the profound rooting in the field of the professional lighting technology belong to our core competences and therefore guarantee extremely innovative and reliable products, excellent support and professional service in every aspect.

*Designed & developed in Germany*

ROXX® products are developed and designed in Germany. Always in tight consultation with our customers and experts who will eventually be working with these tools. This ensures innovative, easy-to-use and performance-oriented solutions, which provide added value for our customers.

*Made to last*

Recommended for permanent outdoor use, most ROXX® products feature additional corrosion protection and enhanced IP66 equipment protection, thereby providing that crucial extra for a wider range of applications. In addition to architectural or theme park applications, even fixed installations in coastal or offshore areas with high salt exposure can be reliably implemented over long periods of time.

### 2.2. CLUSTER B2 FC

All CLUSTER products can be easily connected both horizontal and vertically, by using the integrated C-Lok system. The series is made to enable toolless multiple array configurations, scalable from a single vertical line, to massive matrix like arrays. Due IP65 rating all products are outdoor ready and protected from ingress of dust and rain. There are several mounting options – Camlock mounts on top and back enable the use of Omega-Brackets, Yokes can be attached to mounting points on all sides, or the internal C-Lok system can be used for seamless interconnection. Pre-Link Magnets on top and side help to align the fixtures, giving an incredible user-friendly operation and save interlocking. A specially designed rigging bracket is used for seamless connection of multiple Blinders, to avoid gaps due to bracing of the truss structure by variable, sliding mounting positions. Floor extensions can be used to create vertical structures in single or double rows.

The Full Color version reproduces the same look by using its warmwhite LED's in combination with RGB and Amber, plus the full range of user adjustable color mixing and tunable white.

## 3. GENERAL PRODUCT INFORMATION

### 3.1. Scope of delivery

- ⊕ 1x CLUSTER B2 FC
- ⊕ Power cord with plug (EU country specific, if not ordered differently)
- ⊕ Pre-installed PUK

We're offering a wide range of professional accessories (optional). Please see under menu 6 or at our website [www.roxxlight.com](http://www.roxxlight.com)

### 3.2. Control Functions

- 1CH DWE, 2CH DWE, 4CH DWE, 9CH DWE+, 6CH STROBE, 6CH RGB, 10CH BASIC RGB, 14CH BASIC RGB, 11CH SECTION RGB, 11CH COMP RGB, 13CH STANDARD RGB (default), 22CH STANDARD RGB, 24CH EXTENDED RGB, 33CH EXTENDED RGB, 10CH DIRECT, 12CH DIRECT, 17CH DIRECT, 24CH DIRECT, 41CH DIRECT
- RDM (Remote Device Management)
- Stand Alone Functions including auto programs, LEE adjusted color macros, custom color templates and Tunable White
- Master & Slave

### 3.3. Features

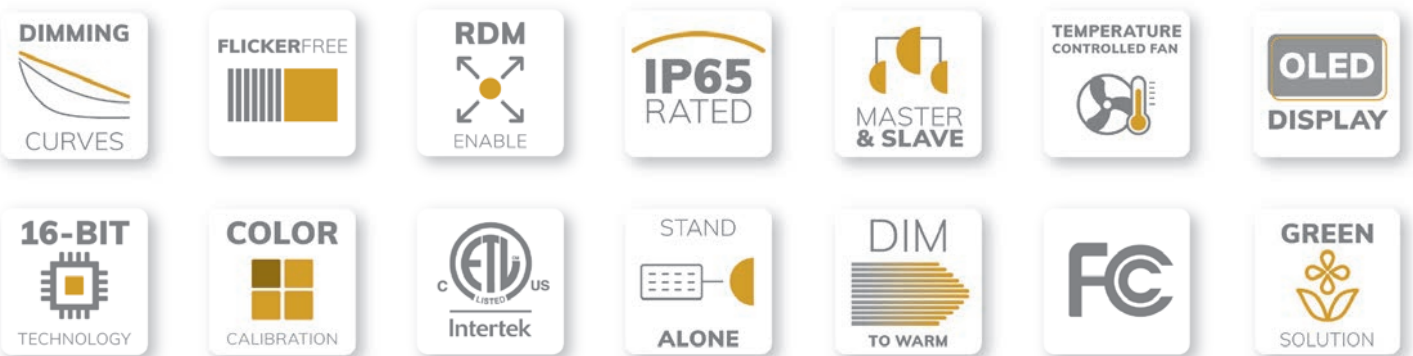



## 4. INSTALLATION & SETUP

### 4.1 Physical Installation and Rigging

ROXX CLUSTER B2 FC may be installed in any orientation. For this purpose the product provides several options:

#### Standing:

The fixtures Yoke includes two M8 inner threads to install the optional ROXX YOKE FLOOR EXTENSION.

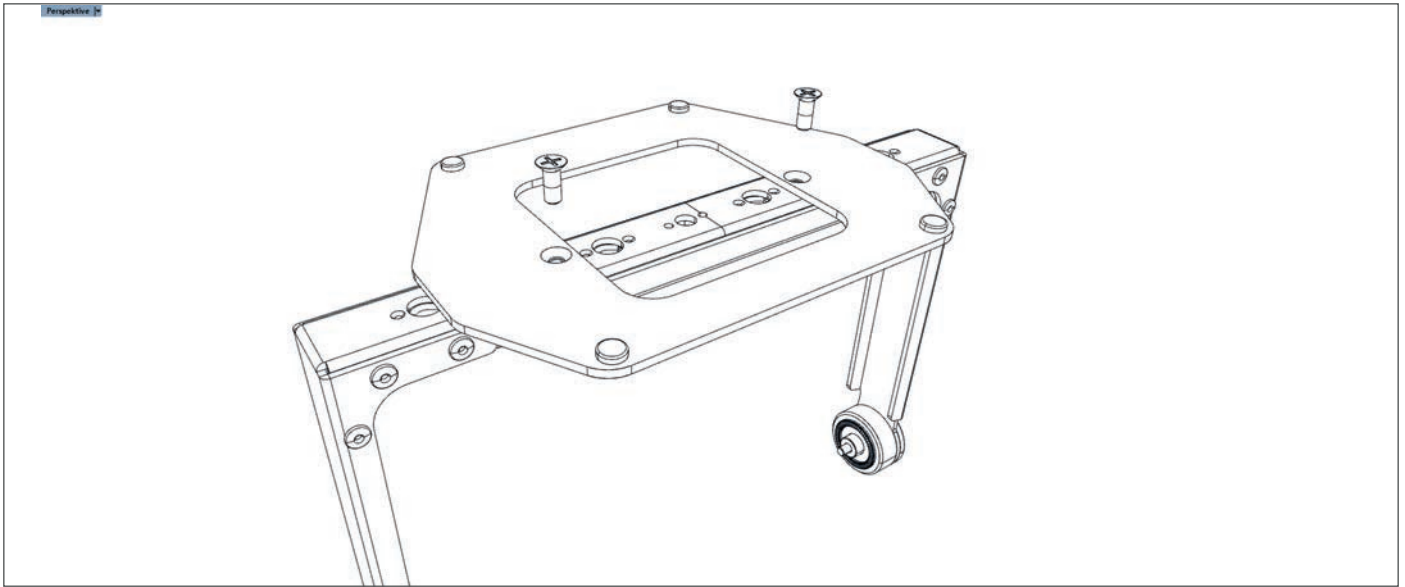

#### Hanging:

The fixture can be installed in different ways:

1. Directly by integrated 1/4 turn Camlocks on top- or rear side

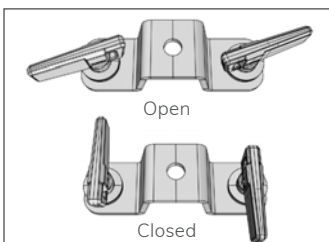
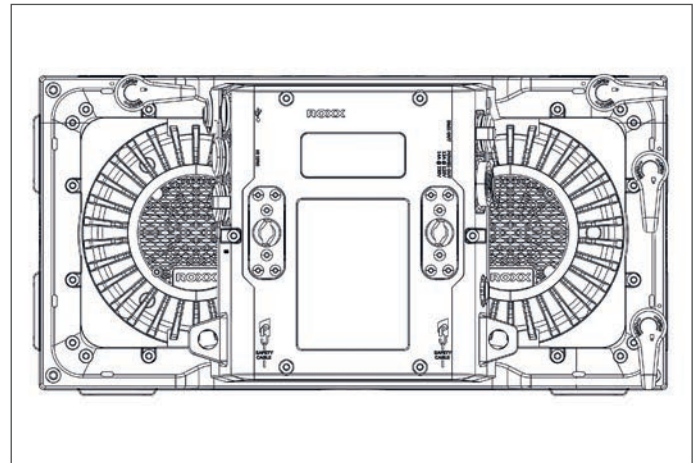
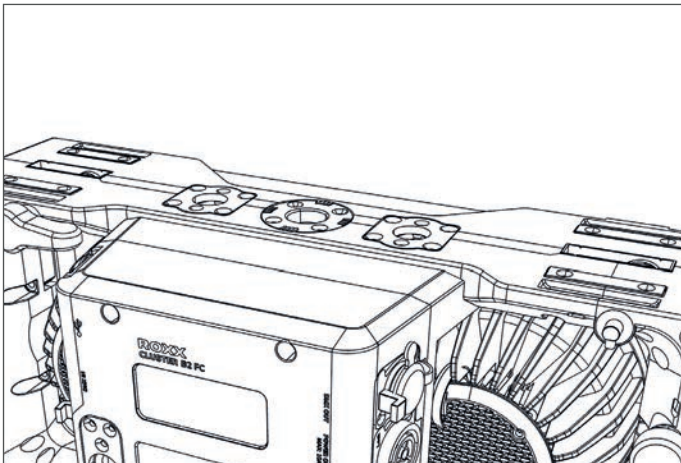

2. By included yoke with several mounting points:

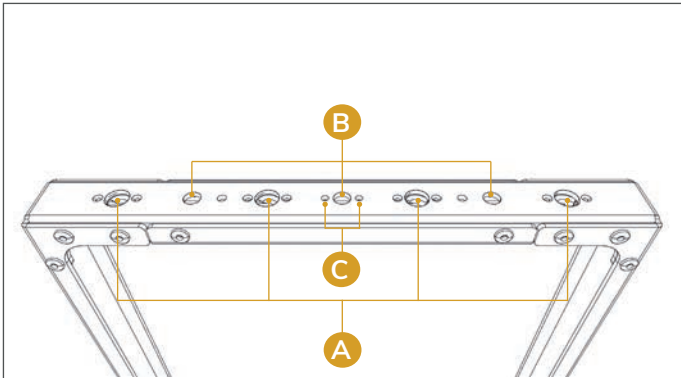

Multiple mounting points:

A: 3x Camlock with ¼ turn adapters

B: 3x M12 / ½"

C: 1x TV Spigot

3. Using optional ROXX RIGGING BRACKET

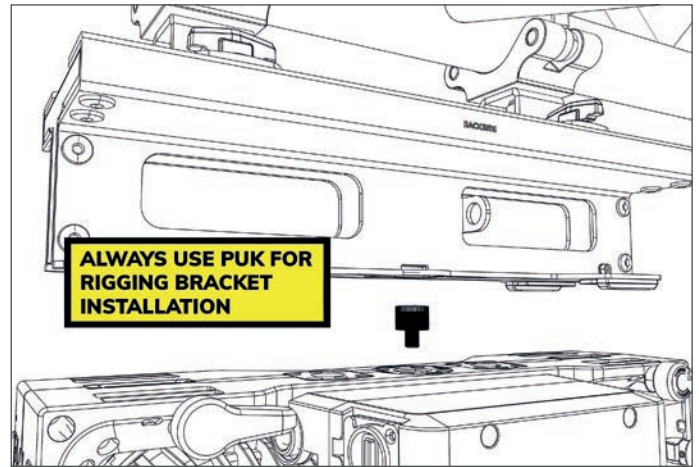
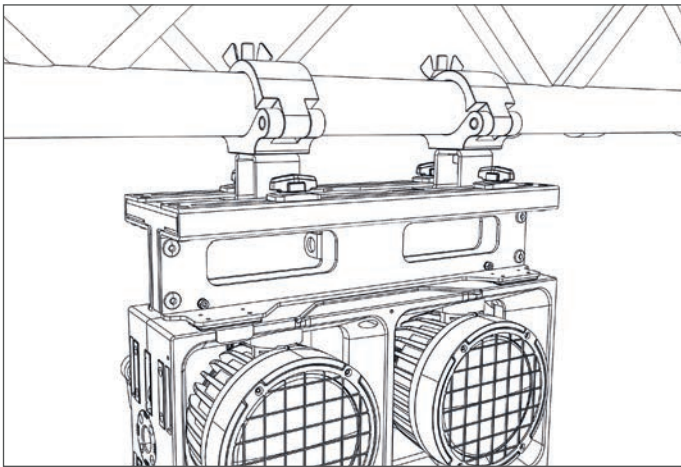

For seamless connection of multiple Blinders, to avoid gaps due to bracing of the truss structure by variable, sliding mounting positions.



### Product Clustering

All CLUSTER products can be easily connected both horizontal and vertically, by using the integrated C-Lok system. The series is made to enable toolless multiple array configurations, scalable from a single vertical line, to massive matrix like arrays.

To connect the devices with each other, proceed as follows in sequence:

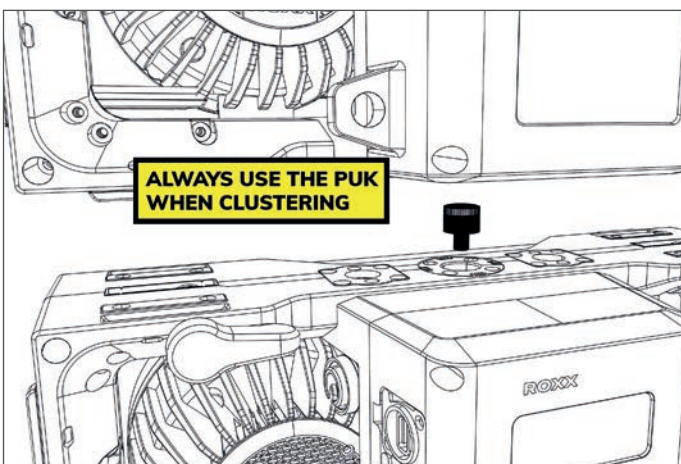

1. Bring the devices together with the respective top and bottom side.

A so-called centering puk is pre-installed on the top of every cluster device.

This should always be installed when connecting the devices to each other.

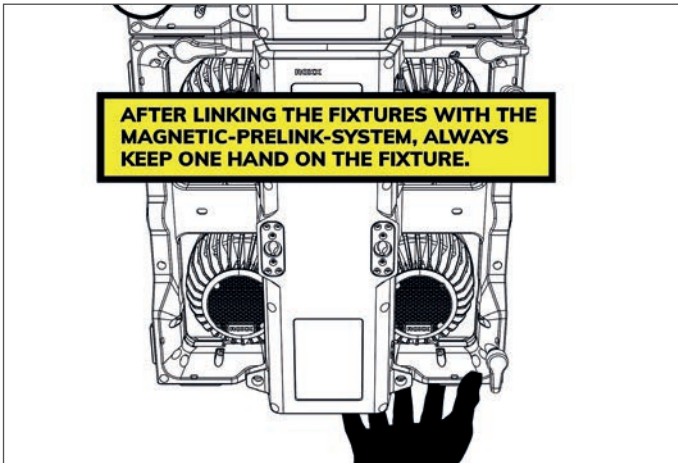

2. Pre-Link Magnets on top and side help to align the fixtures due cluster process and giving support operation for convenient and save interlocking.



**Important Note:**

Even though the pre-link magnet system is strong enough to hold the devices together, at least one hand must always remain on the device for support during the connection.

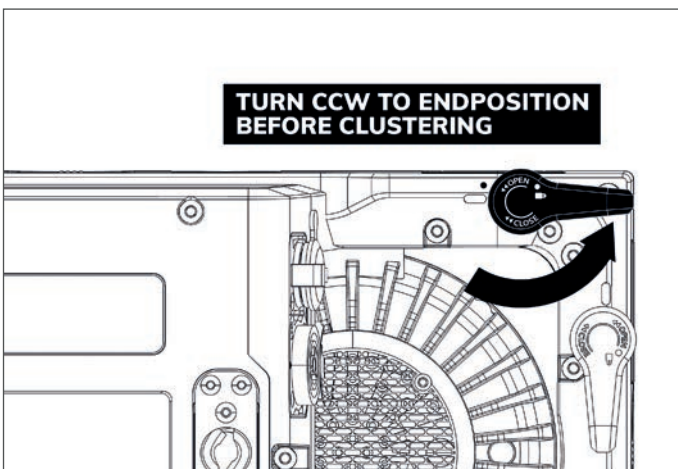

3. Make sure that the C-Lok hooks are turned counterclockwise (CCW) to the end-position first before you finally lock the C-Loks.

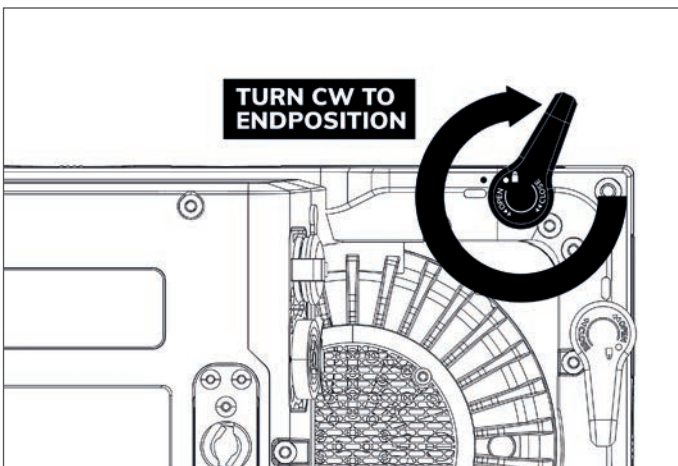

4. For locking all C-Lok's, please turn them clockwise into end-position.

**Note:**

As soon as both dot indicators are in line, the C-Lok is securely locked



**Maximum Tensile and Torsion Load**

Before setting up Cluster configurations, be aware of the maximum tensile and torsion load, listed here below. Also make sure the mounting clamps are capable of supporting the total weight of your configuration.

The different rigging options of all Cluster products result in different maximum tensile and torsion loads that must not be exceeded for a safe overhead installation.

**The maximum loads listed here below take into account the 10-fold safety!**

**1. Rigging by integrated 1/4 turn Camlocks on top- or rear side**

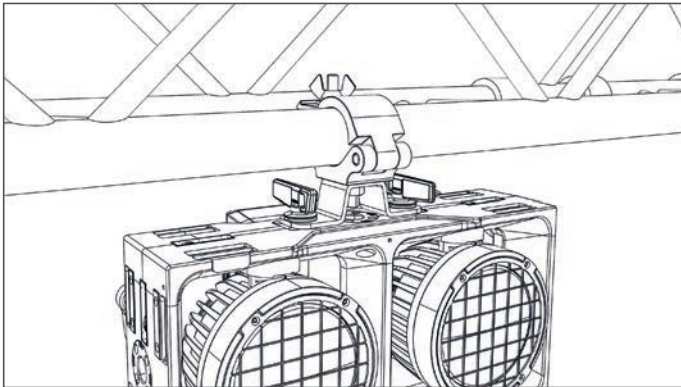

Max. Tension Load: 90kg  
Max. Torsion Load: 18.703 Nmm

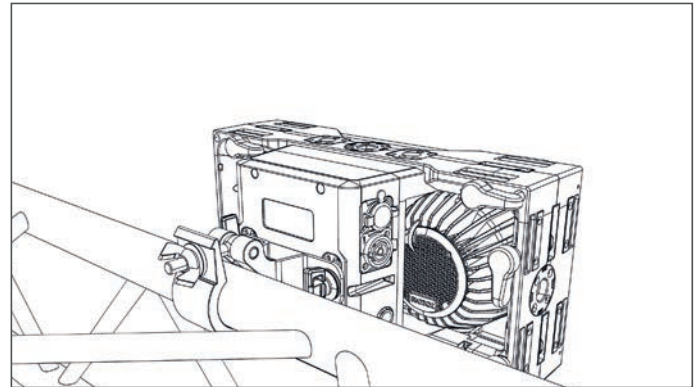

Max. Tension Load: 90kg  
Max. Torsion Load: 14.201 Nmm

**2. Rigging by Yoke with multiple mounting points**

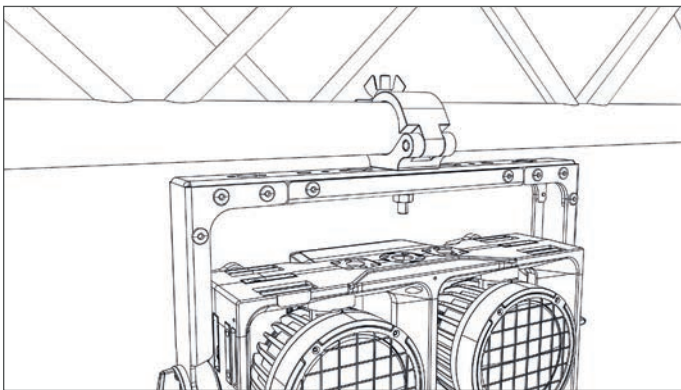

**a. With 1x Mounting Clamp**

Max. Tension Load: 40kg  
Max. Torsion Load: 4.414 Nmm

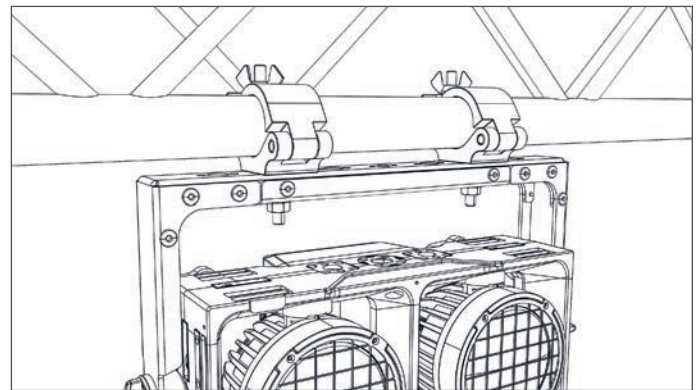

**b. With 2x Mounting Clamp**

Max. Tension Load: 77kg  
Max. Torsion Load: 7.308 Nmm

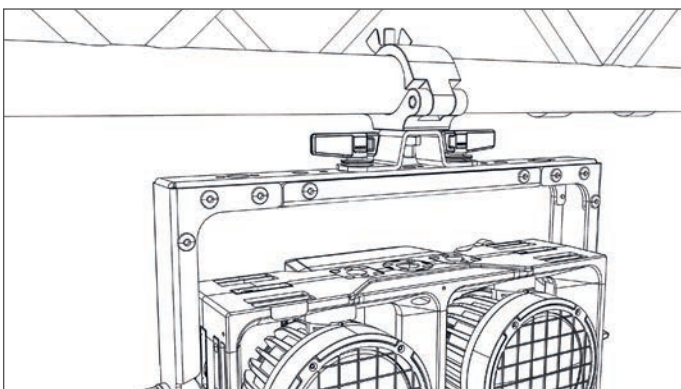

**c. With 1x Omega Bracket**

Max. Tension Load: 51kg  
Max. Torsion Load: 4.768 Nmm

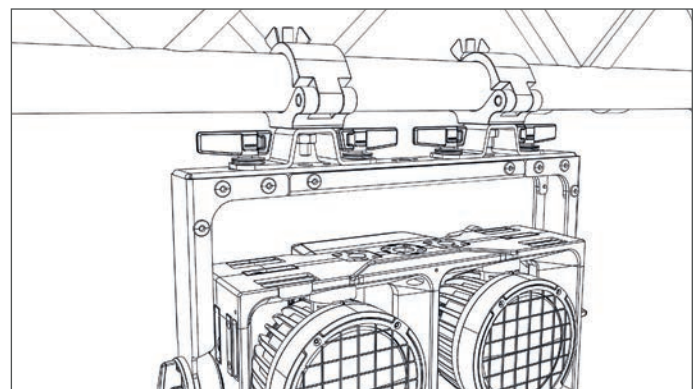

**d. With 2x Omega Bracket**

Max. Tension Load: 90kg  
Max. Torsion Load: 5.943 Nmm

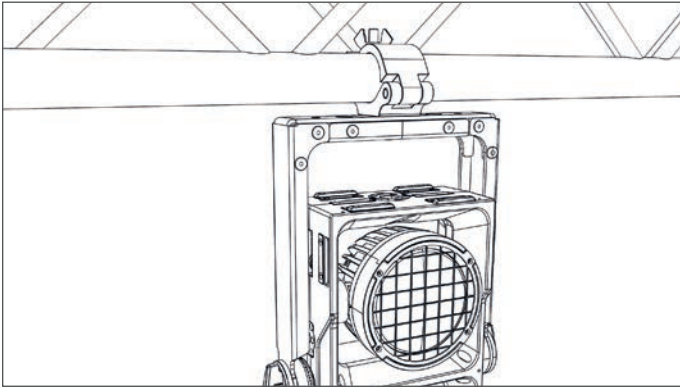

**e. YOKE 2.2 with 1x Mounting Clamp**

Max. Tension Load: 88kg

Max. Torsion Load: 8.238Nmm

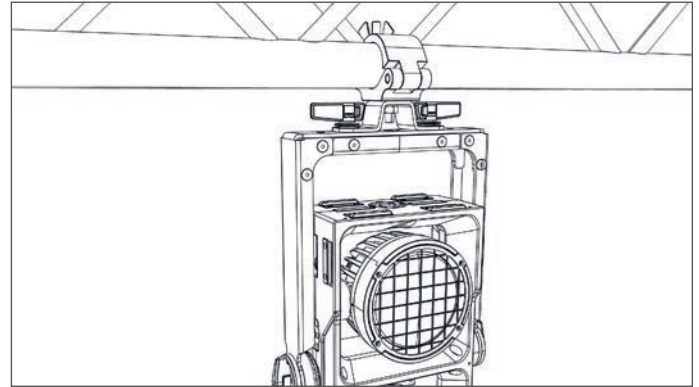

**f. YOKE 2.2 with 1x Omega Bracket**

Max. Tension Load: 66kg

Max. Torsion Load: 6.476Nmm

3. Using optional ROXX RIGGING BRACKET with 2x Mounting Clamps

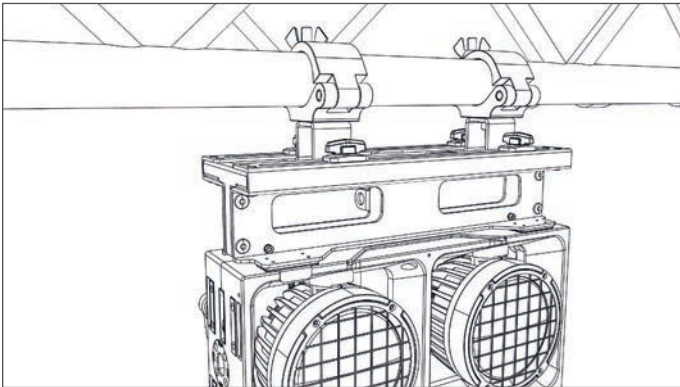

Max. Tension Load: 72kg

Max. Torsion Load: 6.326 Nmm



**Important Note:**

Please be aware of using the centering PUK for safe RIGGING BRACKET installation to the CLUSTER device.

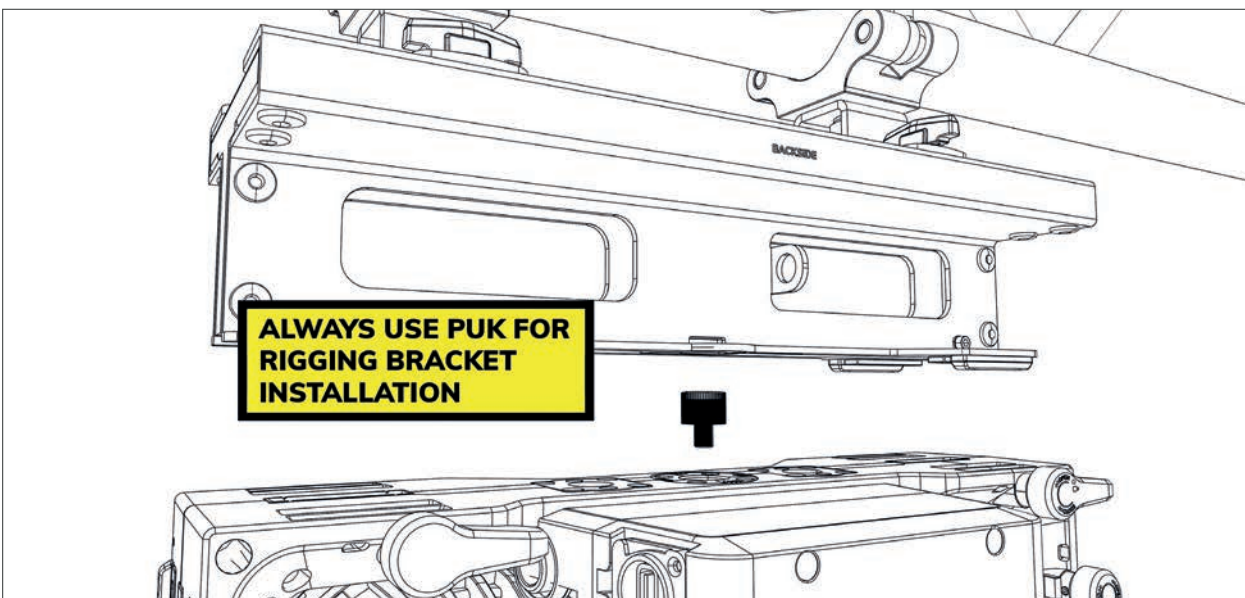

## 4.2 Connections\*

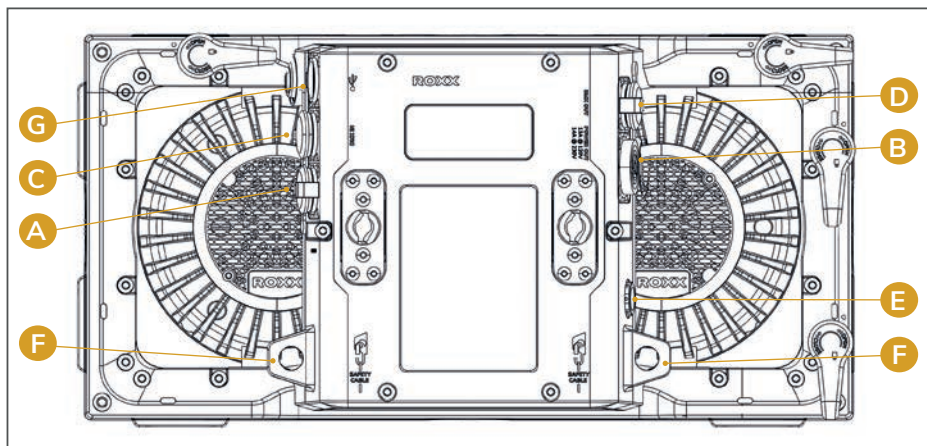

**A: Mains In:** IP65 Power input connector with rubber sealing cap. Connect using the provided power cable (when not in use, always close with rubber sealing cap).

**B: Mains Out:** IP65 Power output connector with rubber sealing cap. Provides power to additional fixtures. Ensure that the total power consumption of all daisy-chained devices connected do not exceed 8A (Ampere)! (when not in use, always close with rubber sealing cap).

**C: DMX IN:** Male IP65 5-pin XLR connector (when not in use, always close with rubber sealing cap).

**D: DMX OUT:** Female IP65 5-pin XLR connector when not in use, always close with rubber sealing cap).

**E:** GoreTex

**F:** Safety Eyelet

**G:** IP65 USB port for firmware updates

### ⓘ \*Note:

**In order to provide protection from spraying water, in accordance with protection class IP65, special IP65-rated XLR connectors must be used correctly with the DMX input and output sockets, or they must be closed using the rubber sealing caps. When connected correctly, or when sealed correctly with the rubber sealing caps, the POWER IN and POWER OUT sockets are protected from spraying water, as in accordance with IP65.**

### 4.2.1. AC Power

The CLUSTER B2 FC operates on any 100–260 V, 50/60 Hz AC mains power supply with a maximum power consumption of 220W.

Connect the fixture to AC power using the supplied cable or a similar one with Neutrik powerCON TRUE1 NAC3FX-W or a compatible type, to ensure the correct ingress protection (IP).

For temporary installations, the mains cable must be fitted with a grounded connector intended for exterior use. The fixture must be grounded/earthed and be able to be isolated from AC power. The AC power supply must incorporate a fuse or circuit breaker for fault protection.

Wire Color (EU models)	Wire Color (US models)	Conductor	Symbol
Brown	Black	Live	L
Blue	White	Neutral	N
Yellow / Green	Green	Ground (earth)	⊕ or ⊚



### Warning!

Read “Safety Informations” starting on page 3 before connecting the fixtures to AC mains power! Do not connect the fixture to an electrical dimmer system, as doing so may cause damage that is not covered by the product warranty!

#### 4.2.2. DMX Connection

The CLUSTER B2 FC is fully controllable by DMX (USITT DMX512-A standard, based on RS-485) and RDM.

##### 4.2.2.1. Cable Connection

If using a cabled DMX system, connect the DMX IN cable to the input connector (male 5-pin XLR connector) and DMX OUT cable to the output (female 5-pin XLR connectors).

For outdoor installations, use only IP65-rated XLR connectors.

Use shielded twisted pair cable designed for RS-485 devices. The cables are daisy chained between the fixtures, and up to 32 fixtures can be connected to the same DMX link. Up to 300 meters (1000ft.) of cable is achievable with high quality DMX cables. All DMX links must be terminated in the last fixture by connecting a DMX termination plug to the last fixture's 5 pin DMX out connector.

Standard microphone cable is not suitable for transmitting DMX.

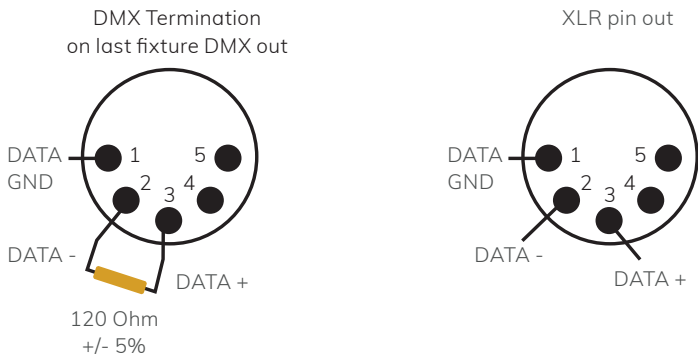

## 5. OPERATION

### 5.1 Start up\*

Once the fixture is connected to AC power, the boot process starts and the following information will appear on the display:

“Ready to ROXX”, the product name and the current software version.



After this process, the fixture is ready for operation, and starts in the previously enabled mode.

**\*Note:**

**During boot process the fan spins up quickly to blow out some possible dust from last use.**

### 5.2 Control Display\*

OLED Display with Touch-Sensitive controls



Press **ENTER** to access the selection menu for system settings or confirm changes.



Press **ESC** to take a step back in the menu.



Press **arrows to scroll up and down** inside the menu and change values, such as DMX address.

**\*Note:**

**For a smooth navigation thru the menu settings, please make sure the display surface is dry and dust free.**

**After approximately 1 minute of inactivity inside the menu settings, the display will automatically jump back to home screen.**

### 5.3 Display Short Cuts\*

Short Cuts

For some always recurring functions the fixture allows quick and user-friendly access at home screen over some display control short-cuts:

#### User Reset or Factory Reset\*



Pressing **ESC+ENTER** simultaneously a Factory Reset or User Reset can be started.

By using the up/down arrows the Factory- or User Reset can be selected.

For confirming press **ENTER**, to jump back please press **ESC**.

**\*Note:**

**After Factory Reset all fixture settings are set back to factory default values.**

**After User Reset all user selected reset functions and user default values will set back.**

**Also a short self-test will start immediately while dimming in and out each single color.**



## Display Off



Pressing ESC + arrow down simultaneously the display backlight function will set to off and the display will turn off immediately. Once a control is pressed the display backlight will turn on.

## Manual display flip function\*



The fixture includes an auto display flip function by default.

To use the manual display flip function please disable the auto flip function under Settings / Display first. Once the auto display flip function is disabled you can use the manual display flip function by pressing arrow up + arrow down simultaneously. The display will rotate 180. By pressing both arrows simultaneously again the display will flip back.

### **Note:**

Once the display is flipped both Up / Down controls will work according to the display rotation.

## 5.4 Configuration

### Home Screen

After boot process the fixture is ready for operation and starts in the previously enabled mode. At home screen the following information will appear, depending on the current operating mode:

- A** DMX Address
- B** Operating Mode (DMX Mode, Quick Light or Standalone Mode)
- C** Next available DMX address depending on the fixtures DMX footprint
- D** External Data protocol (DMX).
- E** The dot indicates the active protocol

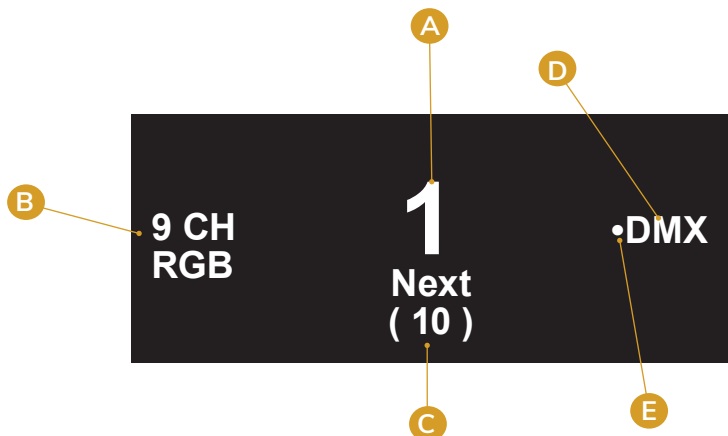

### 5.4.1 Set DMX Start Address (Direct Access)

At Home Screen the DMX address can be changed directly by using the up and down arrows. During this process the DMX address starts blinking, once it's confirmed by pressing ENTER it stops blinking.

If the DMX address will not be confirmed by ENTER within 10 seconds, the display will jump back and show the DMX address from before and stops blinking.

### 5.4.2 Selecting DMX Mode\*

At home screen please press ENTER to access to the main menu (level 1).

While using UP / DOWN arrows, please select the menu item "DMX Mode" and confirm by pressing ENTER.

In the following sub-menu (level 2), you can now choose between 18 different DMX operating modes while using the UP/Down arrows and confirm by pressing ENTER or jump back by pressing ESC.

After confirmation the display will jump back to main menu (level 1). Press ESC for homescreen, here the selected DMX mode will be displayed.

**ⓘ \*Note:**

**For detailed information about the several DMX modes including channel assignment please see our DMX Control chart.**

Level 1

Menu
➔ DMX Mode
Stand Alone
Slave
Settings
System Info

Level 2

DMX Mode
➔ 1CH DWE
2CH DWE
4CH DWE
9CH DWE+
6CH STROBE
6CH RGB
10CH BASIC RGB
14CH BASIC RGB
11CH SECTION RGB
<b>13CH STANDARD RGB</b> (default)
22CH STANDARD RGB
24CH EXTENDED RGB
33CH EXTENDED RGB
10CH DIRECT
12CH DIRECT
17CH DIRECT
24CH DIRECT
41CH DIRECT

### 5.4.3 Stand Alone\*

Press ENTER to access to main menu (level 1).

While using the UP / DOWN arrows, please select the menu item “Stand Alone” and confirm by pressing ENTER.

In the following sub-menu (level 2), you can now choose between 5 different Stand Alone operating modes (Auto, Color Macro, Quick Color, Tunable White, User Color) ,Stop Stand Alone and Color Settings functions while using the UP/Down arrows and confirm by pressing ENTER or jump back by pressing ESC.

To finally use Stand Alone programs please make sure DMX is disconnected to the fixture, as this protocol has priority.

#### Stop Stand Alone

To stop a running Stand Alone mode immediately, please select “Stop Stand Alone” and confirm by pressing ENTER. The display will automatically jump back to level 1.

Level 1

Menu
DMX Mode
➤ Stand Alone
Slave
Settings
System Info

Level 2

Stand Alone Mode
➤ Stop Stand Alone
Auto
Color Macro
Quick Color
Tunable White
User Color
Color Settings
Master

#### Auto\*

Select “Auto” by using the up/down arrows and press ENTER.

Here at sub-menu (level 3), you can choose between 10 different Auto Effects (Effect 1 - 10) and Stop Program. Using the Up/Down arrows you can select one of the 10 Effects and confirm by pressing ENTER or step back by ESC.

After confirming your preferred Effect, you can now adjust speed and brightness at level 4.

To adjust speed, please use the UP / DOWN arrows to select the menu item “Speed”, and confirm with ENTER. After use UP / DOWN arrows to adjust the speed value between 000-100 and confirm by ENTER or jump back by ESC.

To adjust brightness please select “Dim” as per the procedure previously described and confirm with ENTER. After use UP / DOWN arrows again to adjust the brightness value between 000-100 and confirm by ENTER or jump back by ESC.

Once it’s confirmed or denied the display will automatically jump back to level 3.

To stop running a selected Effect please chose “Stop Program” at level 3 or "Stop Stand Alone" at level 2.

For returning back to homescreen please press ESC three times.

At homescreen the selected Stand Alone mode “Auto” and the selected program will be displayed.

#### ⓘ \*Note:

Using arrows UP /DOWN at homescreen Auto programs can be directly changed according to the list.

Level 1

Menu
DMX Mode
➔ Stand Alone
Slave
Settings
System Info

Level 2

Stand Alone Mode
Stop Stand Alone
➔ Auto
Color Macro
Quick Color
Tunable White
User Color
Color Settings
Master

Level 3

Auto
➔ Stop Program
Effect 1
Effect 2
Effect 3
Effect 4
Effect 5
Effect 6
Effect 7
Effect 8
Effect 9
Effect 10

Level 4

Program
➔ Speed <0-100>
<b>(Default 50)</b>
Dim <0-100>

## Auto Effect 1

### Color Macro\*

46 different color macros (34x matched LEE color filters, 6 LED colors and 6 different Whites) are available as presets. For each the brightness can be adjusted separately.

Level 1

Menu
DMX Mode
➔ Stand Alone
Slave
Settings
System Info

Level 2

Stand Alone Mode
Stop Stand Alone
Auto
➔ Color Macro
Quick Color
Tunable White
User Color
Color Settings
Master

Level 3

Color Macro
Color Off
➔ Color Macros
Color Macro Chart
Dim <0-100>

To select a color macro please press ENTER to access to main menu (level 1).

While using the UP / DOWN arrows select the menu item "Stand Alone" and confirm

by pressing ENTER. After please select the item "Color Macro" by using the up/down arrows and press ENTER again.

Using UP and DOWN controls, select your desired color preset and confirm with ENTER.

At level 3 you can adjust the brightness for the color preset between 000-100. Confirm by ENTER. For color blackout choose the item "Color Off".

**ⓘ Note: Using UP / DOWN arrows at homescreen Color Macros can be changed according to the list.**

Level 4

Gels - Color Macros for Standalone Mode			Gels - Color Macros for Standalone Mode			Gels - Color Macros for Standalone Mode		
Pos.	Gel Name	Color Number	Pos.	Gel Name	Color Number	Pos.	Gel Name	Color Number
1	Red	100% Red LED	17	jade	LEE 323	33	Special Med Lavender	LEE 343
2	Fire	LEE 019	18	Blue	100% Blue LED	34	Ultimate Violet	LEE 707
3	Medium Red	LEE 027	19	Sky Blue	LEE 068	35	Magical Magenta	LEE 795
4	Primary Red	LEE 106	20	Tokyo Blue	LEE 071	36	Chrysalis Pink	LEE 798
5	Med Amber	LEE 020	21	Light Blue	LEE 118	37	Specia KH Lavender	LEE 799
6	Dark Amber	LEE 022	22	Marine Blue	LEE 131	38	Bulb White	2700K
7	Deep Amber	LEE 104	23	Med Blue	LEE 132	39	Halogen White	3200K
8	Orange	LEE 105	24	Congo Blue	LEE 181	40	Neutral White	4200K
9	Deep Golden Amber	LEE 135	25	Mikkel Blue	LEE 716	41	Daylight White	5600K
10	Yellow	LEE 101	26	Rose Pink	LEE 002	42	Cold White I	6000K
11	Green	100% Green LED	27	Med Pink	LEE 036	43	Cold White II	6300K
12	Lime Green	LEE 088	28	Light Lavender	LEE 052	44	Amber (only if available)	100% Amber LED
13	Moss Green	LEE 089	29	Lavender	LEE 058	45	Lime (only if available)	100% Lime LED
14	LEE Green	LEE 121	30	Magenta	LEE 113	46	Cyan (only if available)	100% Cyan LED
15	Primary Green	LEE 139	31	Mauve	LEE 126			
16	Jas Green	LEE 738	32	Smokey Pink	LEE 127			

**Quick Color\***

The standalone mode “Quick Color” allows a direct adjustment of the single LED colors R, G, B, A, W, Dimmer and Shutter.

Level 1

Menu
DMX Mode
➤ Stand Alone
Slave
Settings
System Info

Level 2

Stand Alone Mode
Stop Stand Alone
Auto
Color Macro
➤ Quick Color
Tunable White
User Color
Color Settings
Master

Level 3

Quick Color
Dimmer <0-100>
Shutter <0-255>
Red <0-255>
Green <0-255>
Blue <0-255>
Amber <0-255>
White <0-255>

To adjust your Quick Color please press ENTER to access to main menu (level 1). While using the UP / DOWN arrows select the menu item “Stand Alone” and confirm by pressing ENTER. After please select the item “Quick Color” by using the up/down arrows and press ENTER again. Using UP and DOWN controls, select your desired color and confirm with ENTER. After you can adjust the brightness for the color between 000-255 and confirm by ENTER. Besides the individual color mix also a master dimmer can be adjusted between 000-100. For strobe effects please adjust the Shutter value between 000-255.

**\*Note:** Please see detailed explanation for strobe effects inside DMX chart at the end of this manual. Using UP/DOWN arrows at homescreen you can change Quick Color’s dimmer value.

### Tunable White\*

The standalone mode “Tuneable White” allows the color temperature (CCT) to be adjusted from 2.000K – 10.000K in 100K steps. Besides brightness and shutter also a +/- green and magenta correction is available.

Level 1	Level 2	Level 3																				
<table border="1"> <thead> <tr> <th>Menu</th> </tr> </thead> <tbody> <tr> <td>DMX Mode</td> </tr> <tr> <td>█ Stand Alone</td> </tr> <tr> <td>Slave</td> </tr> <tr> <td>Settings</td> </tr> <tr> <td>System Info</td> </tr> </tbody> </table>	Menu	DMX Mode	█ Stand Alone	Slave	Settings	System Info	<table border="1"> <thead> <tr> <th>Stand Alone Mode</th> </tr> </thead> <tbody> <tr> <td>Stop Stand Alone</td> </tr> <tr> <td>Auto</td> </tr> <tr> <td>Color Macro</td> </tr> <tr> <td>Quick Color</td> </tr> <tr> <td>█ Tunable White</td> </tr> <tr> <td>User Color</td> </tr> <tr> <td>Color Settings</td> </tr> <tr> <td>Master</td> </tr> </tbody> </table>	Stand Alone Mode	Stop Stand Alone	Auto	Color Macro	Quick Color	█ Tunable White	User Color	Color Settings	Master	<table border="1"> <thead> <tr> <th>Tunable White</th> </tr> </thead> <tbody> <tr> <td>CCT &lt;2900&gt;</td> </tr> <tr> <td>TINT &lt;000&gt; (+/-127)</td> </tr> <tr> <td>Dimmer &lt;0-255&gt;</td> </tr> <tr> <td>Shutter &lt;0-255&gt;</td> </tr> </tbody> </table>	Tunable White	CCT <2900>	TINT <000> (+/-127)	Dimmer <0-255>	Shutter <0-255>
Menu																						
DMX Mode																						
█ Stand Alone																						
Slave																						
Settings																						
System Info																						
Stand Alone Mode																						
Stop Stand Alone																						
Auto																						
Color Macro																						
Quick Color																						
█ Tunable White																						
User Color																						
Color Settings																						
Master																						
Tunable White																						
CCT <2900>																						
TINT <000> (+/-127)																						
Dimmer <0-255>																						
Shutter <0-255>																						

Starting from home screen press ENTER to access to main menu (level 1).  
 While using the UP / DOWN arrows select the menu item “Stand Alone” and confirm by pressing ENTER.  
 After please select the item “Tunable White” by using the up/down arrows and press ENTER again.  
 Using UP and DOWN controls to select your desired menu item, confirm by ENTER and adjust the desired value by up and down controls and confirm all entries with ENTER.

**ⓘ \*Note:**

**Tint values**

- 000 = no function/neutral
- 001 - 127 = + green
- 001 to - 127 = - green

**ⓘ \*Note:** Using UP/DOWN arrows at homescreen the selected CCT value can be changed in +/- 100K steps.  
**Shutter:** Please see detailed explanation for strobe effects inside DMX chart at the end of this manual.

### User Color\*

The standalone mode “User Color” allows to store up to 5 customized color presets out of Red, Green, Blue, Amber, White, brightness and shutter.

Level 1	Level 2	Level 3	Level 4																													
<table border="1"> <thead> <tr> <th>Menu</th> </tr> </thead> <tbody> <tr> <td>DMX Mode</td> </tr> <tr> <td>█ Stand Alone</td> </tr> <tr> <td>Slave</td> </tr> <tr> <td>Settings</td> </tr> <tr> <td>System Info</td> </tr> </tbody> </table>	Menu	DMX Mode	█ Stand Alone	Slave	Settings	System Info	<table border="1"> <thead> <tr> <th>Stand Alone Mode</th> </tr> </thead> <tbody> <tr> <td>Stop Stand Alone</td> </tr> <tr> <td>Auto</td> </tr> <tr> <td>Color Macro</td> </tr> <tr> <td>Quick Color</td> </tr> <tr> <td>Tunable White</td> </tr> <tr> <td>█ User Color</td> </tr> <tr> <td>Color Settings</td> </tr> <tr> <td>Master</td> </tr> </tbody> </table>	Stand Alone Mode	Stop Stand Alone	Auto	Color Macro	Quick Color	Tunable White	█ User Color	Color Settings	Master	<table border="1"> <thead> <tr> <th>User Color</th> </tr> </thead> <tbody> <tr> <td>Color 1</td> </tr> <tr> <td>Color 2</td> </tr> <tr> <td>Color 3</td> </tr> <tr> <td>Color 4</td> </tr> <tr> <td>Color 5</td> </tr> </tbody> </table>	User Color	Color 1	Color 2	Color 3	Color 4	Color 5	<table border="1"> <thead> <tr> <th>User Color</th> </tr> </thead> <tbody> <tr> <td>Dimmer &lt;0-100&gt;</td> </tr> <tr> <td>Shutter &lt;0-255&gt;</td> </tr> <tr> <td>Red &lt;0-255&gt;</td> </tr> <tr> <td>Green &lt;0-255&gt;</td> </tr> <tr> <td>Blue &lt;0-255&gt;</td> </tr> <tr> <td>Amber &lt;0-255&gt;</td> </tr> <tr> <td>White &lt;0-255&gt;</td> </tr> </tbody> </table>	User Color	Dimmer <0-100>	Shutter <0-255>	Red <0-255>	Green <0-255>	Blue <0-255>	Amber <0-255>	White <0-255>
Menu																																
DMX Mode																																
█ Stand Alone																																
Slave																																
Settings																																
System Info																																
Stand Alone Mode																																
Stop Stand Alone																																
Auto																																
Color Macro																																
Quick Color																																
Tunable White																																
█ User Color																																
Color Settings																																
Master																																
User Color																																
Color 1																																
Color 2																																
Color 3																																
Color 4																																
Color 5																																
User Color																																
Dimmer <0-100>																																
Shutter <0-255>																																
Red <0-255>																																
Green <0-255>																																
Blue <0-255>																																
Amber <0-255>																																
White <0-255>																																

To define a User Color please press ENTER to access to main menu (level 1).  
 While using the UP / DOWN arrows, please select the menu item “Stand Alone” and confirm by pressing ENTER.

Select the item menu "User Color" by using the up/down controls and press ENTER.

Using UP and DOWN select your desired preset number (Color 1 -5) and confirm with ENTER.

Use UP and DOWN controls to select your desired color, confirm by ENTER and adjust the value by up and down controls between 000-255 and confirm all entries with ENTER.

With dimmer you can adjust the allover brightness of your User Color. Shutter allows several strobe effects. Once your color mix is ready, jump back by ESC. Your individual color is stored under the selected color preset now.

**ⓘ \*Note: All five User Colors are also available by DMX at Color Macro channel.**

**For detailed information please see Color Macro Chart at the end of this manual.**

**Using UP/DOWN arrows at homescreen the Color Macros can be changed according to the list.**

**Shutter: Please see detailed explanation for strobe effects inside DMX chart at the end of this manual.**

### Color Settings\*

Here at "Color Settings" you can chose your preferred working color mode for all Stand Alone modes. Either Color Calibration or RAW. Chose Color Calibration if the fixture should work accroding to the settings at Color Calibration, either Full Calibration or CCT Calibration, RAW works according to the settings at RAW Balance, either RAW or User Calibrated.

Level 1

Menu
DMX Mode
➤ Stand Alone
Slave
Settings
System Info

Level 2

Stand Alone Mode
Stop Stand Alone
Auto
Color Macro
Quick Color
Tunable White
User Color
➤ Color Settings
Master

Level 3

Color Settings
➤ Color Calibration
RAW

### Master

If you want to set up a Master-Slave-System, select "On" at the fixture, that should be the Master and controls all connected Slaves. Keep this "Off", if you don't need it to prevent DMX collisions.

Level 1

Menu
DMX Mode
➤ Stand Alone
Slave
Settings
System Info

Level 2

Stand Alone Mode
Stop Stand Alone
Auto
Color Macro
Quick Color
Tunable White
User Color
Color Settings
➤ Master

Level 3

Master
On
➤ Off

### 5.4.5 Slave Mode\*

Slave Mode allows same model fixtures to be controlled by the “Master” fixture via DMX. The “Master” device should run in Stand Alone mode, all “Slave” devices should set to “Slave”.

Level 1

Menu
DMX Mode
Stand Alone
▀ Slave
Settings
System Info

To select “Slave” please press ENTER to access to main menu (level 1). While using the UP / DOWN arrows, please select the menu item “Slave” and confirm by pressing ENTER. Now this unit is set to “Slave”. Please connect the slave and the master devices (same model) with a DMX cable and enable one of your preferred standalone mode on the master device. Once the Stand Alone mode is activated all slave devices will follow the master device.

**ⓘ Note: All devices should use same software version.**

**Once Stand Alone mode is disabled at Master unit the display of Slave unit starts to blink.**

### 5.4.5 Settings

Level 1

Menu
DMX Mode
Stand Alone
Slave
▀ Settings
System Info

Main Menu	Menu level 2	Menu level 3	Menu level 4	Description	
Settings	Display	Display Flip	<on/off>	On= Flip control panel display by 180° (e.g. for overhead installation) Off= normal control panel display	
		Backlight	<on/off>	On= controls permanent on, display itself will deactivate after 60 minutes of inactivity Off= controls and display deactivation after approximately 1 minute of inactivity	
		Auto Lock	<on/off>	On= Automatically locks the controls after approximately 1 minute of inactivity. After attempted input the display shows: „Locked!“ Unlock process: press arrows up, down, up, down consecutively	
	Startup Mode (using last adjustments of specific Standalone Modes)	<b>DMX</b>			Select your default operating mode when fixture is powered on
		Auto			
		Color Macro			
		Quick Color			
		Tunable White			
		User Color			



Main Menu	Menu level 2	Menu level 3	Menu level 4	Description
Settings	DMX Fail	<b>Hold</b>		Hold= last command retains
		Blackout		Blackout= Activates Blackout
		Emergency Light		Emergency Light= Fixtures changes to 5600K
	Dimmer Curve	Linear		Linear= Light intensity increases linear with DMX value
		<b>Exponential</b>		Exponential= Light intensity can be set more smooth at lower DMX values and broadly at higher DMX values.
		Logarithmic		Light intensity can be broadly adjusted at lower DMX values and more smooth at higher DMX values
		S-Curve		Light intensity can be adjusted smoothly at lower and higher DMX values and broadly at medium DMX values
	Dimmer Response	LED		The LED responds abruptly to it's DMX values
		Medium		The LED responds with medium delay to DMX value changes at brightness
		<b>Halogen</b>		The LED responds similar to a halogen fixture with soft changes at brightness.
	Redshift	<b>On / Off</b>	On= Activates Redshift, Off= Deactivates Redshift	Redshift function simulate traditional halogen fixtures while dimming down. Redshift affects only between 2700-3500K.
	Color Calibration (affects to corresponding DMX modes and Stand Alone)	Full Calibration		CCT and RGB color calibration available for perfect color consistency from unit to unit
		<b>CCT Calibration</b>		Only CCT Calibration, but RAW colors for White color consistency from unit to unit, but maximum saturation on colors
	RAW Balance (affects RAW Mode in DMX and Stand Alone Modes)	<b>RAW</b>		R,G,B,A,W with maximum value of brightness
		User Calibration	Red 1 <0-255>	individual color calibration for R,G,B,A,W
			Green 1 <0-255>	
			Blue 1 <0-255>	
			Amber 1 <0-255>	
	White 1 <0-255>			
	RAW Balance (affects RAW Mode in DMX and Stand Alone Modes)	User Calibration	Red 2 <0-255>	individual color calibration for R,G,B,A,W
			Green 2 <0-255>	
			Blue 2 <0-255>	
			Amber 2 <0-255>	
			White 2 <0-255>	
	LED Frequency	800 Hz		Select preferred LED PWM frequency
		<b>1200 Hz</b>		
		2000 Hz		
		3600 Hz		
		12000 Hz		
		25000 Hz		
Fan	<b>Auto</b>		Adjust fan speed relative to internal fixture temperature	
	Silent		Low fan speed for silent operation	
	Fan Off		Fan Off	
	Max. Power		High fan speed for maximum cooling effect	

Main Menu	Menu level 2	Menu level 3	Menu level 4	Description
Settings	Invert Mapping	On / <b>Off</b>		Inverts the pixel layout of the fixture
	Transfer Configuration	Including DMX Address		Transfer the same menu settings of this fixture to all the other in daisy chain (same model), either with DMX address or without. After power off and on again, the transferred settings should stay the same.
		<b>Without DMX Address</b>		
	LED Mode	Illumination		Normal output for constant illumination
		<b>Boost</b>		Boost for temporarily highest output for blinder and strobe effects
	USB Update	Yes		Run firmware update via USB port
		<b>No</b>		Do not run firmware update via USB port
	Factory / User Reset	Factory Reset	Are you sure to reset? Confirm by pressing ENTER, cancel with ESC	Restores all factory defaults including User Colors, but no User defaults.
User Reset		Are you sure to reset? Confirm by pressing ENTER, cancel with ESC	Restores all User Reset according to the User Preset List. Timer Function and DMX address restore to Factory default. Once User Reset is activated a fixture self test will start.	

Main Menu	Menu level 2	Menu level 3	Menu level 4	Menu Level 5	Description
Settings	Factory / User Reset	User Reset List	1CH DWE, 2CH DWE, 4CH DWE, 9CH DWE+, 6CH STROBE, 6CH RGB, 10CH BASIC RGB, 14CH BASIC RGB, 11CH SECTION RGB, <b>13CH STANDARD RGB</b> , 22CH STANDARD RGB, 24CH EXTENDED RGB, 33CH EXTENDED RGB, 10CH DIRECT, 12CH DIRECT, 17CH DIRECT, 24CH DIRECT, 41CH DIRECT		Select your User Reset defaults
			Display Flip	<on/off>	
			Backlight	<on/off>	
			Auto Lock	<on/off>	
			Startup Mode	<DMX/Auto/Color Macro, Quick Color, Tunable White User Color>	
			DMX Fail	<Hold/Blackout/Emergency (5600K)>	
			Dimmer Curve	<Linear, <b>Exponential</b> , Logarithmic, S-Curve>	
			Dimmer Response	<LED, Medium, <b>Halogen</b> >	
			Redshift	<on/off>	
			LED Frequency	<800Hz, <b>1200Hz</b> , 2000Hz, 3600Hz, 12000Hz, 25000Hz>	
			Color Calibration	Full Calibration / <b>CCT Calibration</b>	
			RAW Balance	<b>RAW</b> / User Calibration	
			Fan	< <b>Auto</b> , Silent, Studio, Fan Off, Max. Power>	
			Invert Mapping	<off, on>	
			Transfer Configuration	<including DMX address / <b>without DMXaddress</b> >	
LED Mode	<Illumination, <b>Boost</b> >				
USB Update	<yes/no>				

## Dimmer Curves

LINEAR

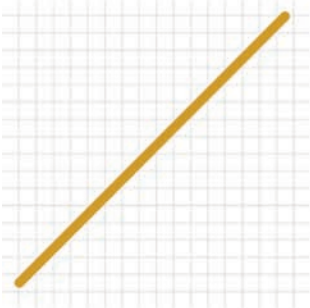

EXPONENTIAL

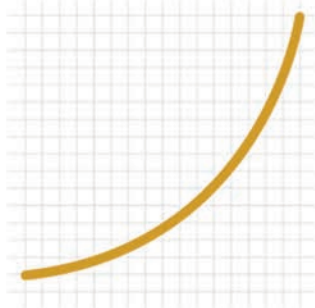

LOGARITHMIC



S-CURVE



### 5.4.6 System Info

Level 1

Menu
DMX Mode
Stand Alone
Slave
Settings
➤ System Info

Main Menu	Menu level 2	Menu level 3	Menu level 4
System Info	Firmware Version	vx.xx	Display installed firmware version
	Serial Number	202xxxxxxx	
	RDM UID	0X6a6axxxxxxx	Display unique RDM ID for identification
	Temperatures	LED 1: Celsius/Fahrenheit : XXX°C / XXX °F LED 2: Celsius/Fahrenheit : XXX°C / XXX °F	Display LED 1-2 temperature by celsius and fahrenheit
	Power on Time	Total: LED 1: xxxxxhours LED 2: xxxxxhours	Display fixture total power on time
	LED on Time	Total: xxxxxhours	Display LED 1-2 total power on time
	Errors	Errors information	Display error codes

## 6. ACCESSORIES



Yoke 2.2  
Art.: 13907001



Yoke 4.3  
Art.: 13907101

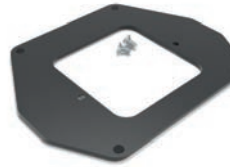

Floor Extension  
Art.: 13907201



Rigging Bracket G2  
Art.: 13907411



Omega Bracket ST  
Art.: 90900002



Floor Bracket  
Art.: 13908501



Amptown Case 4 pcs./8 pcs. Art.: 13907411  
Amptown Case 2 pcs/4 pcs Art.: 13907511



CS Case 5 pcs B2/S2. Art.: 13908201  
CS Case 5 pcs B4 Art.: 13908301



Line Array  
Fly Bar  
Art.: 13909501



Line Array  
Side Bracket Set  
Art.: 13909601



Line Array  
Backbone 4  
Art.: 13909701



Line Array  
Backbone 2+2  
Art.: 13909801



Line Array  
Floor Bracket  
Art.: 13909901

## 7. TECHNICAL DATA / DIAGRAMS

### 7.1 Technical drawings and measurements

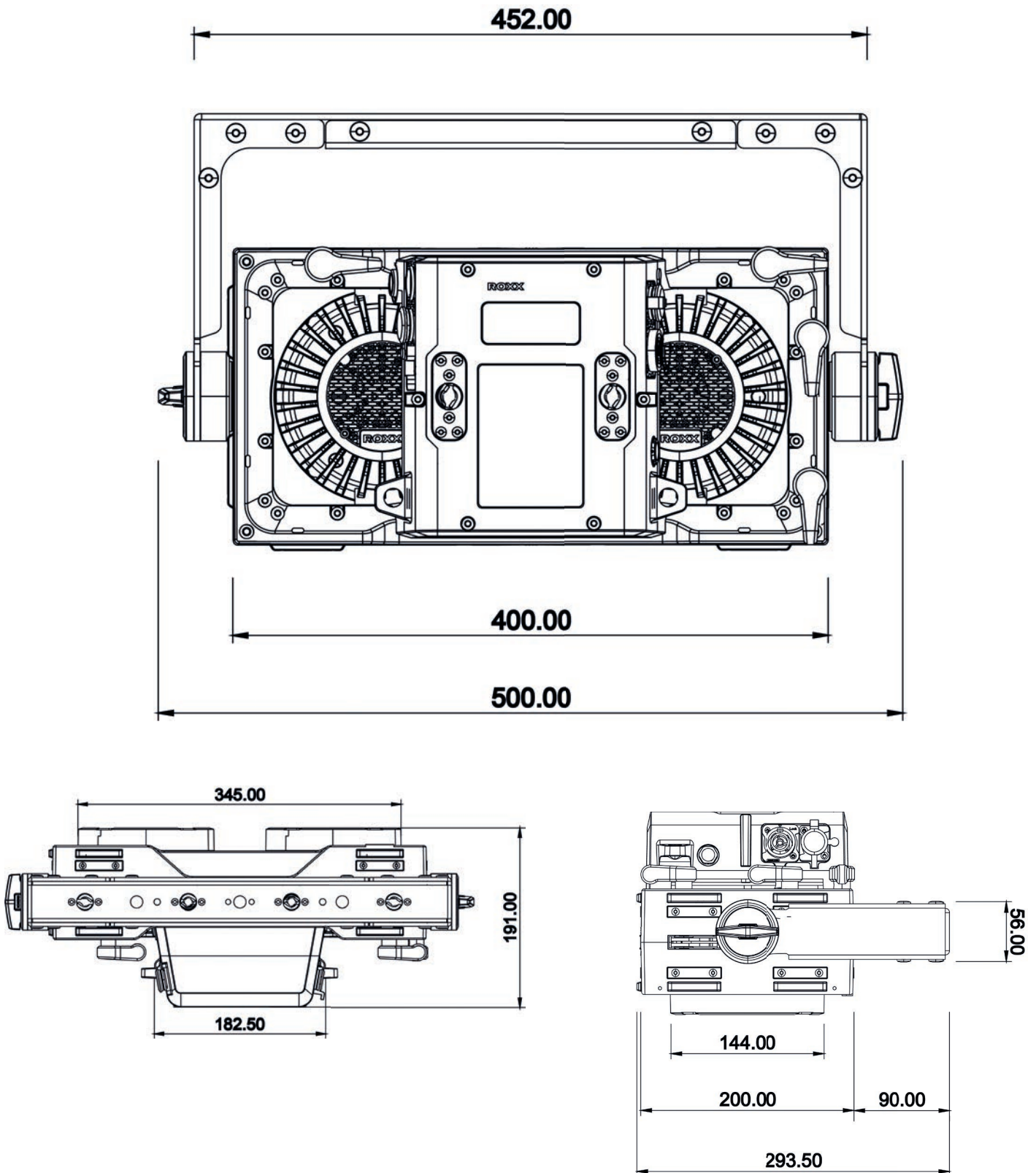

## 7.2 IP Rating

ROXX products conform to officially classified IP standard levels. CLUSTER B2 FC is rated to IP65 when using the covers for the housing parts. IP stands for Ingress Protection and IP65, according to classified standard, means shielded against dust and high-pressure jets of water from any side.

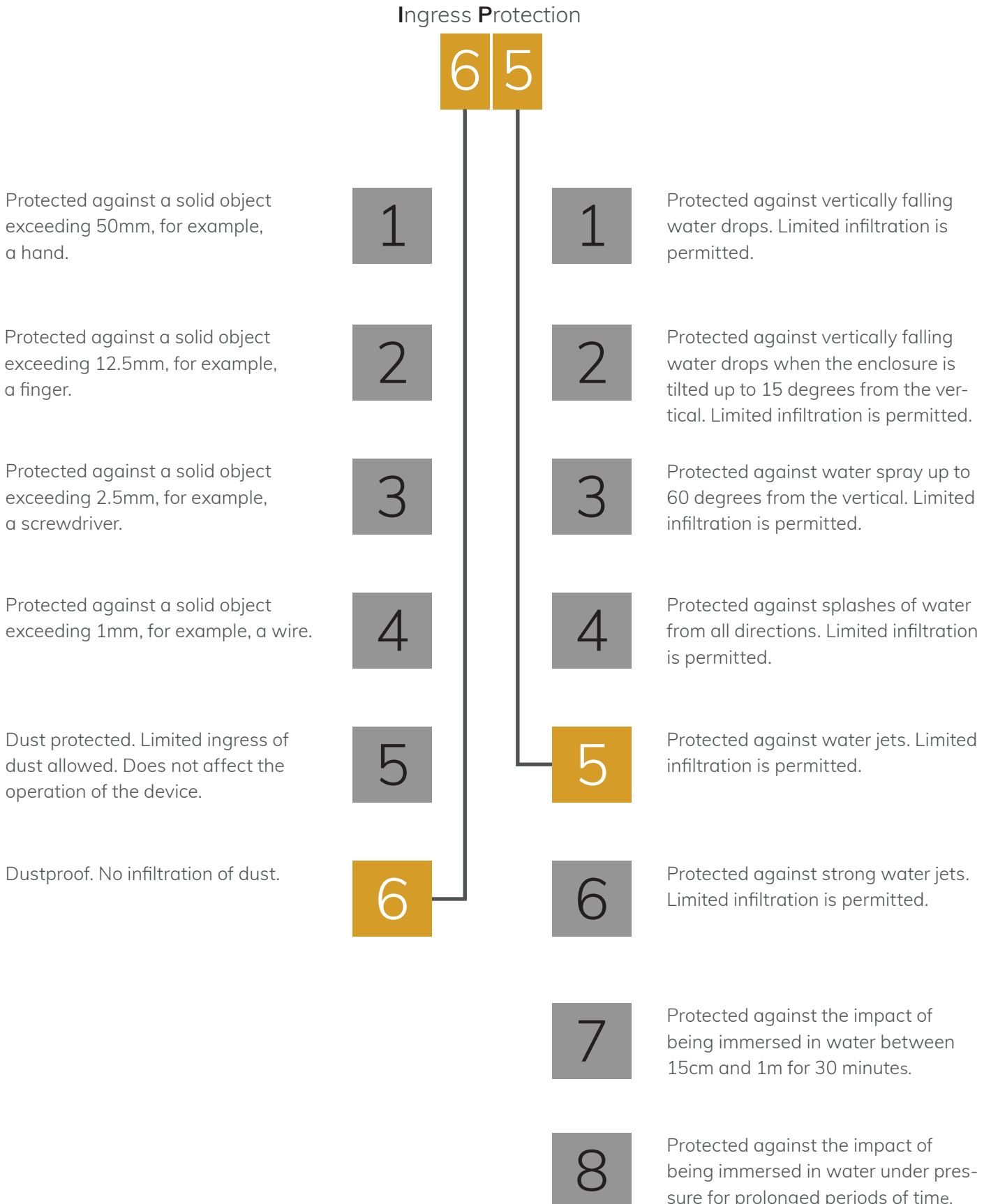

### 7.3 Technical Data

Photometrics	
LED expected lifetime	50.000 hours
Lightsource	2x 300W Red, Green, Royal Blue, Amber, Warm-White
Type of optical system	Reflector with Compound Eye Lens
LED PWM Frequency	selectable 800Hz, 1.200Hz, 2.000Hz, 3.600Hz, 12kHz, 25kHz
Beam angles (50%)	50°
Maximum Field angles (10%)	87°
Color temperature range	2000-10.000K
CRI/Ra	90 @ 5600K / 86 @ 2900K
Efficacy (max)	26,15 lm/W
Luminous flux	16.215 lm
illuminance Lux @ 1m / 3,3ft (@ 2900K)	17.801lx / 1654fcd
illuminance Lux @ 3m / 9,8ft (@ 2900K)	1920lx / 178fcd
illuminance Lux @ 5m / 16,4ft (@ 2900K)	721lx / 67fcd
illuminance Lux @ 7m / 23,0ft (@ 2900K)	398lx / 37fcd
illuminance Lux @ 10m / 32,8ft (@ 2900K)	199lx / 18fcd
Thermal Characteristics	
Cooling	Active, Forced Air, Temperature-regulated
Humidity (max.)	95%
Temperature range, Operating	-40°C to 45°C
Temperature range, Start-up	-20°C to 45°C
Temperature range, Storage	-40°C to 80°C
Thermal Protection	Automatic overtemperature protection
Electrical Data	
AC Power, max	90 – 285V 50/60Hz
AC Power, nominal	100 – 240V 50/60Hz
Electrical protection	Overload protection with automatic recover
Max power consumption (Boost Mode)	620W
Constant power consumption (Illumination Mode)	220W
Power Max. Out	13A @ 230V / 9A @ 120V
Power Linking @ Max Power Consumption (Boost Mode)	4 units @ 230V / 1 unit @ 120V
Power Linking @ Constant Power Consumption (Illumination Mode)	15 units @ 230V / 6 units @ 120V
Power Factor	0.974 PF (230V) / 0.996 PF (120V)
Power Supply Unit	Inbuilt auto-ranging electronic switch-mode

## 7.3 Technical Data

Operator & Controller	
DMX Functions	Master Dimmer, Master Dimmer Fine, Shutter, Duration, Dimmer 1-2, Dimmer 1-2 Fine, Red 1-2, Red 1-2 Fine, Green 1-2, Blue 1-2, Blue Fine 1-2, Amber 1-2, Warm-White 1-2, CTC 1-2, Tint 1-2, Color Macro 1-2, Color Macro Crossfade 1-2, Dimmer Curve, Dimmer Response, Redshift, Effect, Device Settings
DMX channels	1CH DWE, 2CH DWE, 4CH DWE, 9CH DWE+, 6CH STROBE, 6CH RGB, 10CH BASIC RGB, 14CH BASIC RGB, 11CH SECTION RGB, 11CH COMP RGB, 13CH STANDARD RGB (default), 22CH STANDARD RGB, 24CH EXTENDED RGB, 33CH EXTENDED RGB, 10CH DIRECT, 12CH DIRECT, 17CH DIRECT, 24CH DIRECT, 41CH DIRECT
DMX modes	19
Protocol	USITT DMX512A
RDM ANSI E1.20	Auto Program, Editor, Color Macro, Quick Color, Tunable White, User Color, Timer
Setting and addressing	OLED graphical display / 4 controls
RDM ANSI E1.20	Auto Program, Editor, Color Macro, Quick Color, Tunable White, User Color, Timer
Standalone mode	Auto Program, Color Macro, Quick Color, Tunable White, User Color
Wireless DMX	n.a.
Indicator	OLED graphical display
Controls	4 touch sensitive, backlighted controls
Strobe	0-20Hz
DMX I/O	IP65 XLR 5-pin male/female
Power In	TRUE1 compatible input & link-thru sockets
USB Firmware Update	IP65 USB socket
Dimensions & Weight	
IP class	IP65
IK class	IK08
Body material	Aluminum, Nylon
Lens material	Tempered glass front
Net dimensions (w x h x d)	400 x 200 x 191mm
Net dimensions inches	15,75 x 7,87 x 7,52 inches
Net weight (incl. Yoke)	10,5 kg (23,15lbs)
Tilt	360°
Tilt Locking System	Locking system with tothing and angle indicator
Included / Optional	
Included items	Yoke 4.1, 2m Power Cable, Puk
Optional Accessories	Yoke 2.2, Yoke 4.3, Yoke Floor Extension, Rigging Bracket, Omega Bracket ST
Color options	Black – RAL 9004 (Standard) / Custom color – any RAL (on request)
Installation	
Mounting point by Yoke (included)	3x 13mm / 1/2" holes, 1x centric TV Spigot attachment, 3x integrated Camlocks for Omega Brackets
Mounting point on fixture	1/4 turn Omega Bracket on top and rear side
Mounting point with optional Rigging Bracket	2x 13mm / 1/2" holes for Clamp fixation
Orientation	Any
Rigging possibilities	Hanging or ceiling / pendant mount
Safety features	2x rear mount for safety wire
Minimum distance from flammable materials	0,3 meters (11,8 inch)



## 7.4 DMX Charts / Color Macro Charts / CCT Chart

<b>1CH DWE</b>	<b>13CH STANDARD RGB (default)</b>
<b>2CH DWE</b>	<b>22 CH STANDARD RGB</b>
<b>4CH DWE</b>	<b>24CH EXTENDED RGB</b>
<b>9CH DWE+</b>	<b>33CH EXTENDED RGB</b>
<b>6CH STROBE</b>	<b>10CH DIRECT</b>
<b>6CH RGB</b>	<b>12CH DIRECT</b>
<b>10CH BASIC RGB</b>	<b>17CH DIRECT</b>
<b>14CH BASIC RGB</b>	<b>24CH DIRECT</b>
<b>11CH SECTION RGB</b>	<b>41CH DIRECT</b>
<b>11CH Comp RGB</b>	

<b>CH</b>	<b>1CH DWE (Calibrated)</b>	<b>2CH DWE (Calibrated)</b>	<b>4CH DWE (Calibrated)</b>	<b>9CH DWE+ (Calibrated)</b>	<b>6CH STROBE (Calibrated)</b>
1	Dimmer	Dimmer 1	Dimmer	Master Dimmer	Master Dimmer
2		Dimmer 2	Dimmer Curve	Shutter	Shutter
3			Dimmer Response	Red	Duration
4			Redshift	Green	Dimmer 1
5				Blue	Dimmer 2
6				CTC	CCT
7				Dimmer Curve	
8				Dimmer Response	
9				Redshift	

CH	6CH RGB (Calibrated)	10CH BASIC RGB (Calibrated)	14CH BASIC RGB (Calibrated)	11CH SECTION RGB (Calibrated)	11CH Comp RGB (Calibrated)
1	Red 1	Master Dimmer	Master Dimmer	Dimmer 1	Dimmer 1
2	Green 1	Shutter	Master Dimmer Fine	Red 1	Red 1
3	Blue 1	Red	Shutter	Green 1	Green 1
4	Red 2	Green	Red	Blue 1	Blue 1
5	Green 2	Blue	Red Fine	CTC 1 (affects RGB 1)	Dimmer 2
6	Blue 2	CTC	Green	Dimmer 2	Red 2
7		Tint	Green Fine	Red 2	Green 2
8		Color Macro	Blue	Green 2	Blue 2
9		Color Macro Crossfade	Blue Fine	Blue 2	Shutter 1+2
10		Device Settings	CTC	CTC 2 (affects RGB 2)	CTC (affects RGB 1+2)
11			Tint	Device Settings	Device Settings
12			Color Marco		
13			Color Macro Crossface		
14			Device Settings		

CH	13CH STANDARD RGB (Calibrated / default)	22CH STANDARD RGB (Calibrated)	24CH EXTENDED RGB (Calibrated)	33CH EXTENDED RGB (Calibrated)
1	Master Dimmer	Master Dimmer	Master Dimmer	Master Dimmer
2	Shutter	Master Dimmer Fine	Shutter	Master Dimmer Fine
3	Dimmer 1	Shutter	Duration	Shutter
4	Red 1	Dimmer 1	Dimmer 1	Duration
5	Green 1	Dimmer 1 Fine	Red 1	Dimmer 1
6	Blue 1	Red 1	Green 1	Dimmer 1 Fine
7	Dimmer 2	Red 1 Fine	Blue 1	Red 1
8	Red 2	Green 1	CTC 1	Red 1 Fine
9	Green 2	Green 1 Fine	Tint 1	Green 1
10	Blue 2	Blue 1	Color Macro 1	Green 1 Fine
11	CTC (all)	Blue 1 Fine	Color Macro Crossfade 1	Blue 1
12	Tint (all)	Dimmer 2	Dimmer 2	Blue 1 Fine
13	Device Settings	Dimmer 2 Fine	Red 2	CTC 1
14		Red 2	Green 2	Tint 1
15		Red 2 Fine	Blue 2	Color Macro 1
16		Green 2	CTC 2	Color Macro Crossfade 1
17		Green 2 Fine	Tint 2	Dimmer 2
18		Blue 2	Color Macro 2	Dimmer 2 Fine
19		Blue 2 Fine	Color Macro Crossfade 2	Red 2
20		CTC (all)	Effect	Red 2 Fine
21		Tint (all)	Dimmer Curve	Green 2
22		Device Settings	Dimmer Response	Green 2 Fine
23			Redshift	Blue 2
24			Device Settings	Blue 2 Fine
25				CTC 2
26				Tint 2
27				Color Macro 2
28				Color Macro Crossfade 2
29				Effect
30				Dimmer Curve
31				Dimmer Response
32				Redshift
33				Device Settings

CH	10CH DIRECT (RAW)	12CH DIRECT (RAW)	17CH DIRECT (RAW)	28CH DIRECT (RAW)	41CH DIRECT (RAW)
1	Red 1	Master Dimmer	Master Dimmer	Master Dimmer	Master Dimmer
2	Green 1	Shutter	Shutter	Shutter	Master Dimmer Fine
3	Blue 1	Red	Dimmer 1	Duration	Shutter
4	Amber 1	Green	Red 1	Dimmer 1	Duration
5	White 1	Blue	Green 1	Red 1	Dimmer 1
6	Red 2	Amber	Blue 1	Green 1	Dimmer 1 Fine
7	Green 2	White	Amber 1	Blue 1	Red 1
8	Blue 2	CTC	White 1	Amber 1	Red 1 Fine
9	Amber 2	Tint	Dimmer 2	White 1	Green 1
10	White 2	Color Macro	Red 2	CTC 1	Green 1 Fine
11		Color Macro Crossfade	Green 2	Tint 1	Blue 1
12		Device Settings	Blue 2	Color Macro 1	Blue 1 Fine
13			Amber 2	Color Macro Crossfade 1	Amber 1
14			White 2	Dimmer 2	Amber 1 Fine
15			CTC (all)	Red 2	White 1
16			Tint (all)	Green 2	White 1 Fine
17			Device Settings	Blue 2	CTC 1
18				Amber 2	Tint 1
19				White 2	Color Macro 1
20				CTC 2	Color Macro Crossfade 1
21				Tint 2	Dimmer 2
22				Color Macro 2	Dimmer 2 Fine
23				Color Macro Crossfade 2	Red 2
24				Effect	Red 2 Fine
25				Dimmer Curve	Green 2
26				Dimmer Response	Green 2 Fine
27				Redshift	Blue 2
28				Device Settings	Blue 2 Fine
29					Amber 2
30					Amber 2 Fine
31					White 2
32					White 2 Fine
33					CTC 2
34					Tint 2
35					Color Macro 2
36					Color Macro Crossfade 2
37					Effect
38					Dimmer Curve
39					Dimmer Response
40					Redshift
41					Device Settings

**1CH DWE (Calibrated / according to selected Tunable White settings at Stand Alone Mode, default 2900K)**

CH	Function	Value	Setting	Remark	Default
1	Dimmer	000-255	0 - 100%		0

**2CH DWE (Calibrated / according to selected Tunable White settings at Stand Alone Mode, default 2900K)**

CH	Function	Value	Setting	Remark	Default
1	Dimmer 1	000-255	0 - 100%		0
2	Dimmer 2	000-255	0 - 100%		0

**4CH DWE (Calibrated / according to selected Tunable White settings at Stand Alone Mode, default 2900K)**

CH	Function	Value	Setting	Remark	Default
1	Dimmer	000-255	0 - 100%		0
2	Dimmer Curve	000-51	No Function - Current Preset from Menu Settings		0
		052-101	Linear Dimmer Curve		
		102-152	Exponential Dimmer Curve		
		153-203	Logarithmic Dimmer Curve		
		204-255	S-Curve Dimmer Curve		
3	Dimmer Response	000-063	No Function - Current Preset from Menu Settings		0
		064-127	LED / fast		
		128-191	Medium		
		192-255	Halogen / slow		
4	Redshift	000-84	No Function - Current Preset from Menu Settings	Redshift affects only between CCT 2700-3500K.	0
		085-170	Redshift Off		
		171-255	Redshift On		

**9CH DWE+ (Calibrated)**

CH	Function	Value	Setting	Remark	Default
1	Master Dimmer	000-255	0 - 100%		0
2	Shutter	000 - 019	Shutter close		20
		020 - 024	Shutter open		
		025 - 064	Strobe 1 (fast ⊕ slow)		
		065 - 069	Shutter open		
		070 - 084	Strobe 2: opening pulse (fast ⊕ slow)		
		085 - 089	Shutter open		
		090 - 104	Strobe 3: closing pulse (fast ⊕ slow)		
		105 - 109	Shutter open		
		110 - 124	Strobe 4: random strobe (fast ⊕ slow)		
		125 - 129	Shutter open		
		130 - 144	Strobe 5: random opening pulse (fast ⊕ slow)		
		145 - 149	Shutter open		

2	Shutter	150 - 164	Strobe 6: random closing pulse (fast ⊕ slow)	20	
		165 - 169	Shutter open		
		170 - 184	Strobe 7: burst pulse (fast ⊕ slow)		
		185 - 189	Shutter open		
		190 - 204	Strobe 8: random burst pulse (fast ⊕ slow)		
		205 - 209	Shutter open		
		210 - 224	Strobe 9: sine wave (fast ⊕ slow)		
		225 - 229	Shutter open		
		230 - 244	Strobe 10: burst (fast ⊕ slow)		
		245 - 255	Shutter open		
3	Red	000-255	0 - 100%	255	
4	Green	000-255	0 - 100%	255	
5	Blue	000-255	0 - 100%	255	
6	CTC (affects RGB)	000 - 004	2900K	according to CTC chart	0
		005-226	2000K-6500K linear in 20-21K steps (please see detailed CTC chart)		
		182-182	5600K		
		226-226	6500K		
		227-255	6621K-10.000K linear in 120-121K steps (please see detailed CTC chart)		
7	Dimmer Curve	000-51	No Function - Current Preset from Menu Settings	0	
		052-101	Linear Dimmer Curve		
		102-152	Exponential Dimmer Curve		
		153-203	Logarithmic Dimmer Curve		
		204-255	S-Curve Dimmer Curve		
8	Dimmer Response	000-063	No Function - Current Preset from Menu Settings	0	
		064-127	LED / fast		
		128-191	Medium		
		192-255	Halogen / slow		
9	Redshift	000-84	No Function - Current Preset from Menu Settings	Redshift affects only between CCT 2700- 3500K.	0
		085-170	Redshift Off		
		171-255	Redshift On		

6CH STROBE MODE (Calibrated)					
CH	Function	Value	Setting	Remark	Default
1	Master Dimmer	000-255	0 - 100%		0
2	Shutter	000 - 019	Shutter close		20
		020 - 024	Shutter open		
		025 - 064	Strobe 1 (fast ⊕ slow)		
		065 - 069	Shutter open		
		070 - 084	Strobe 2: opening pulse (fast ⊕ slow)		
		085 - 089	Shutter open		
		090 - 104	Strobe 3: closing pulse (fast ⊕ slow)		
		105 - 109	Shutter open		
		110 - 124	Strobe 4: random strobe (fast ⊕ slow)		
		125 - 129	Shutter open		
		130 - 144	Strobe 5: random opening pulse (fast ⊕ slow)		
		145 - 149	Shutter open		
		150 - 164	Strobe 6: random closing pulse (fast ⊕ slow)		
		165 - 169	Shutter open		
		170 - 184	Strobe 7: burst pulse (fast ⊕ slow)		
		185 - 189	Shutter open		
		190 - 204	Strobe 8: random burst pulse (fast ⊕ slow)		
		205 - 209	Shutter open		
		210 - 224	Strobe 9: sine wave (fast ⊕ slow)		
225 - 229	Shutter open				
230 - 244	Strobe 10: burst (fast ⊕ slow)				
245 - 255	Shutter open				
3	Duration	000-255	0 - 100% (0ms - 510ms)	only affects to channel 2 - Strobe 1 025-064	0
4	Dimmer 1	000-255	0 - 100%		255
5	Dimmer 2	000-255	0 - 100%		255
6	CCT	000 - 004	5600K	according to CTC chart	0
		005-182	2000K-6500K linear in 20-21K steps (please see detailed CTC chart)		
		182-182	5600K		
		226-226	6500K		
		227-255	6621K-10.000K linear in 120-121K steps (please see detailed CTC chart)		

6CH RGB (Calibrated)					
CH	Function	Value	Setting	Remark	Default
1	Red 1	000-255	0 - 100%		0
2	Green 1	000-255	0 - 100%		0
3	Blue 1	000-255	0 - 100%		0
4	Red 2	000-255	0 - 100%		0
5	Green 2	000-255	0 - 100%		0
6	Blue 2	000-255	0 - 100%		0

10CH BASIC RGB (Calibrated)					
CH	Function	Value	Setting	Remark	Default
1	Master Dimmer	000-255	0 - 100%		0
2	Shutter	000 - 019	Shutter close		20
		020 - 024	Shutter open		
		025 - 064	Strobe 1 (fast ⊕ slow)		
		065 - 069	Shutter open		
		070 - 084	Strobe 2: opening pulse (fast ⊕ slow)		
		085 - 089	Shutter open		
		090 - 104	Strobe 3: closing pulse (fast ⊕ slow)		
		105 - 109	Shutter open		
		110 - 124	Strobe 4: random strobe (fast ⊕ slow)		
		125 - 129	Shutter open		
		130 - 144	Strobe 5: random opening pulse (fast ⊕ slow)		
		145 - 149	Shutter open		
		150 - 164	Strobe 6: random closing pulse (fast ⊕ slow)		
		165 - 169	Shutter open		
		170 - 184	Strobe 7: burst pulse (fast ⊕ slow)		
		185 - 189	Shutter open		
		190 - 204	Strobe 8: random burst pulse (fast ⊕ slow)		
		205 - 209	Shutter open		
		210 - 224	Strobe 9: sine wave (fast ⊕ slow)		
225 - 229	Shutter open				
230 - 244	Strobe 10: burst (fast ⊕ slow)				
245 - 255	Shutter open				
3	Red	000-255	0 - 100%		255
4	Green	000-255	0 - 100%		255
5	Blue	000-255	0 - 100%		255



6	CTC (affects RGB)	000 - 004	5600K	according to CTC chart	0
		005-226	2000K-6500K linear in 20-21K steps (please see detailed CTC chart)		
		182-182	5600K		
		226-226	6500K		
		227-255	6621K-10.000K linear in 120-121K steps (please see detailed CTC chart)		
7	Tint (affects CTC and RGB)		Tint (affects CTC and RGB)	no function	0
		001-127	Magenta -> Neutral		
		128-128	Neutral		
		129-255	Neutral -> Green		
8	Color Macro (override RGB/CTC)		Please see ROXX color macro chart		
9	Color Macro Cross-fade (Transition Time between Color Macros)	000 - 005	No function		0
		006-105	0,1s - 10s (0,1s steps)		
		106-214	11s - 119s (1s steps)		
		215-244	2m - 4m50s (10s steps)		
		245-255	5m - 15m (1m steps)		
10	Device Settings (please see remark *1)	000-029	No function		0
		030-034	Display Backlight On (hold 3s)		
		035-039	Display Backlight Off (hold 3s)		
		040-044	No function		
		045-049	DMX Fail Blackout (hold 3s)		
		050-054	DMX Fail Hold (hold 3s)		
		055-059	DMX Fail - Emergency Light (hold 3s)		
		060-064	No function		
		065-069	Linear Dimmer Curve (hold 1,5s)		
		070-074	Exponential Dimmer Curve (hold 1,5s)		
		075-079	Logarithmic Dimmer Curve (hold 1,5s)		
		080-084	S-Curve Dimmer Curve (hold 1,5s)		
		085-089	No function		
		090-094	LED (Fast) Dimmer Response (hold 1,5s)		
		095-099	Medium Dimmer Response (hold 1,5s)		
		100-104	Halogen (Slow) Dimmer Response (hold 1,5s)		
		105-109	No function		
		110-114	Redshift On (hold 1,5s / affects only between 2700-3500K )		
		115-119	Redshift Off (hold 1,5s)		
		120-124	No function		
125-129	Full Calibration (Colors & CCT / hold 3s)				
130-134	CCT Calibration (RAW Colors / hold 3s)				

10	Device Settings (please see remark *1)	135-139	No function		0
		140-144	LED Frequency 800Hz (hold 3s)		
		145-149	LED Frequency 1200Hz (hold 3s)		
		150-154	LED Frequency 2000Hz (hold 3s)		
		155-159	LED Frequency 3600Hz (hold 3s)		
		160-164	LED Frequency 12kHz (hold 3s)		
		165-169	LED Frequency 25kHz (hold 3s)		
		170-174	No function		
		175-179	Fan Auto (hold 3s)		
		180-184	Fan Silent (hold 3s)		
		185-189	Fan Off (hold 3s)		
		190-194	Fan High Power (hold 3s)		
		195-199	No function		
		200-204	Invert Mapping Off (hold 3s)		
		205-209	Invert Mapping On (hold 3s)		
		210-214	No function		
		215-219	LED Mode - Illumination (hold 1,5s)		
		220-224	LED Mode - Boost (hold 1,5s)		
		225-229	No function		
		230-234	Factory Reset (hold 3s)	Reset only starts if Shutter channel is set to DMX 250	
235-239	User Reset (hold 3s)	Reset only starts if Shutter channel is set to DMX 250 / no self- test by DMX			
240-255	No function				

**14CH BASIC RGB (Calibrated)**

CH	Function	Value	Setting	Remark	Default
1	Master Dimmer	000-255	0 - 100%		0
2	Master Dimmer Fine	000-255	0 - 100%		0
3	Shutter	000 - 019	Shutter close		20
		020 - 024	Shutter open		
		025 - 064	Strobe 1 (fast ⊕ slow)		
		065 - 069	Shutter open		
		070 - 084	Strobe 2: opening pulse (fast ⊕ slow)		
		085 - 089	Shutter open		
		090 - 104	Strobe 3: closing pulse (fast ⊕ slow)		
		105 - 109	Shutter open		
		110 - 124	Strobe 4: random strobe (fast ⊕ slow)		
		125 - 129	Shutter open		
		130 - 144	Strobe 5: random opening pulse (fast ⊕ slow)		
		145 - 149	Shutter open		
		150 - 164	Strobe 6: random closing pulse (fast ⊕ slow)		
		165 - 169	Shutter open		
		170 - 184	Strobe 7: burst pulse (fast ⊕ slow)		
		185 - 189	Shutter open		
		190 - 204	Strobe 8: random burst pulse (fast ⊕ slow)		
		205 - 209	Shutter open		
210 - 224	Strobe 9: sine wave (fast ⊕ slow)				
225 - 229	Shutter open				
230 - 244	Strobe 10: burst (fast ⊕ slow)				
245 - 255	Shutter open				
4	Red	000-255	0 - 100%		255
5	Red Fine	000-255	0 - 100%		255
6	Green	000-255	0 - 100%		255
7	Green Fine	000-255	0 - 100%		255
8	Blue	000-255	0 - 100%		255
9	Blue Fine	000-255	0 - 100%		255
10	CTC (affects RGB)	000 - 004	5600K	according to CTC chart	0
		005-226	2000K-6500K linear in 20-21K steps (please see detailed CTC chart)		
		182-182	5600K		
		226-226	6500K		
		227-255	6621K-10.000K linear in 120-121K steps (please see detailed CTC chart)		
11	Tint (affects CTC and RGB)	0	no function		0
		001-127	Magenta -> Neutral		
		128-128	Neutral		
		129-255	Neutral -> Green		

12	Color Macro (override RGB/CTC)		Please see ROXX color macro chart		0
13	Color Macro Cross-fade (Transition Time between Color Macros)	000 - 005	no function		0
		006-105	0,1s - 10s (0,1s steps)		
		106-214	11s - 119s (1s steps)		
		215-244	2m - 4m50s (10s steps)		
		245-255	5m - 15m (1m steps)		
14	Device Settings (please see remark *1)	000-029	No function		0
		030-034	Display Backlight On (hold 3s)		
		035-039	Display Backlight Off (hold 3s)		
		040-044	No function		
		045-049	DMX Fail Blackout (hold 3s)		
		050-054	DMX Fail Hold (hold 3s)		
		055-059	DMX Fail - Emergency Light (hold 3s)		
		060-064	No function		
		065-069	Linear Dimmer Curve (hold 1,5s)		
		070-074	Exponential Dimmer Curve (hold 1,5s)		
		075-079	Logarithmic Dimmer Curve (hold 1,5s)		
		080-084	S-Curve Dimmer Curve (hold 1,5s)		
		085-089	No function		
		090-094	LED (Fast) Dimmer Response (hold 1,5s)		
		095-099	Medium Dimmer Response (hold 1,5s)		
		100-104	Halogen (Slow) Dimmer Response (hold 1,5s)		
		105-109	No function		
		110-114	Redshift On (hold 1,5s / affects only between 2700-3500K )		
		115-119	Redshift Off (hold 1,5s)		
		120-124	No function		
		125-129	Full Calibration (Colors & CCT / hold 3s)		
		130-134	CCT Calibration(RAW Colors / hold 3s)		
		135-139	No function		
		140-144	LED Frequency 800Hz (hold 3s)		
		145-149	LED Frequency 1200Hz (hold 3s)		
		150-154	LED Frequency 2000Hz (hold 3s)		
		155-159	LED Frequency 3600Hz (hold 3s)		
		160-164	LED Frequency 12kHz (hold 3s)		
		165-169	LED Frequency 25kHz (hold 3s)		
		170-174	No function		
175-179	Fan Auto (hold 3s)				
180-184	Fan Silent (hold 3s)				
185-189	Fan Off (hold 3s)				
190-194	Fan High Power (hold 3s)				

14	Device Settings (please see remark *1)	195-199	No function		0
		200-204	Invert Mapping Off (hold 3s)		
		205-209	Invert Mapping On (hold 3s)		
		210-214	No function		
		215-219	LED Mode - Illumination (hold 1,5s)		
		220-224	LED Mode - Boost (hold 1,5s)		
		225-229	No function		
		230-234	Factory Reset (hold 3s)	Reset only starts if Shutter channel is set to DMX 250	
		235-239	User Reset (hold 3s)	Reset only starts if Shutter channel is set to DMX 250 / no self- test by DMX	
		240-255	No function		

### 11CH SECTION RGB (Calibrated )

CH	Function	Value	Setting	Remark	Default
1	Dimmer 1	000-255	0 - 100%		255
2	Red 1	000-255	0 - 100%		0
3	Green 1	000-255	0 - 100%		0
4	Blue 1	000-255	0 - 100%		0
5	CTC 1 (affects RGB 1)	000 - 004	5600K	according to CTC chart	0
		005-226	2000K-6500K linear in 20-21K steps (please see detailed CTC chart)		
		182-182	5600K		
		226-226	6500K		
		227-255	6621K-10.000K linear in 120-121K steps (please see detailed CTC chart)		
6	Dimmer 2	000-255	0 - 100%		255
7	Red 2	000-255	0 - 100%		0
8	Green 2	000-255	0 - 100%		0
9	Blue 2	000-255	0 - 100%		0
10	CTC 2 (affects RGB 2)	000 - 004	5600K	according to CTC chart	0
		005-226	2000K-6500K linear in 20-21K steps (please see detailed CTC chart)		
		182-182	5600K		
		226-226	6500K		
		227-255	6621K-10.000K linear in 120-121K steps (please see detailed CTC chart)		
11	Device Settings (please see remark *1)	000-029	No function		0
		030-034	Display Backlight On (hold 3s)		
		035-039	Display Backlight Off (hold 3s)		
		040-044	No function		
		045-049	DMX Fail Blackout (hold 3s)		
		050-054	DMX Fail Hold (hold 3s)		

11	Device Settings (please see remark *1)	055-059	DMX Fail - Emergency Light (hold 3s)		0
		060-064	No function		
		065-069	Linear Dimmer Curve (hold 1,5s)		
		070-074	Exponential Dimmer Curve (hold 1,5s)		
		075-079	Logarithmic Dimmer Curve (hold 1,5s)		
		080-084	S-Curve Dimmer Curve (hold 1,5s)		
		085-089	No function		
		090-094	LED (Fast) Dimmer Response (hold 1,5s)		
		095-099	Medium Dimmer Response (hold 1,5s)		
		100-104	Halogen(Slow) Dimmer Response (hold 1,5s)		
		105-109	No function		
		110-114	Redshift On (hold 1,5s / affects only between 2700-3500K )		
		115-119	Redshift Off (hold 1,5s)		
		120-124	No function		
		125-129	Full Calibration (Colors & CCT / hold 3s)		
		130-134	CCT Calibration (RAW Colors / hold 3s)		
		135-139	No function		
		140-144	LED Frequency 800Hz (hold 3s)		
		145-149	LED Frequency 1200Hz (hold 3s)		
		150-154	LED Frequency 2000Hz (hold 3s)		
		155-159	LED Frequency 3600Hz (hold 3s)		
		160-164	LED Frequency 12kHz (hold 3s)		
		165-169	LED Frequency 25kHz (hold 3s)		
		170-174	No function		
		175-179	Fan Auto (hold 3s)		
		180-184	Fan Silent (hold 3s)		
		185-189	Fan Off (hold 3s)		
		190-194	Fan High Power (hold 3s)		
		195-199	No function		
		200-204	Invert Mapping Off (hold 3s)		
		205-209	Invert Mapping On (hold 3s)		
		210-214	No function		
		215-219	LED Mode - Illumination (hold 1,5s)		
		220-224	LED Mode - Boost (hold 1,5s)		
		225-229	No function		
		230-234	Factory Reset (hold 3s)		
235-239	User Reset (hold 3s)	no self-test by DMX			
240-255	no function				

**11CH COMP RGB (Calibrated )**

CH	Function	Value	Setting	Remark	Default
1	Dimmer 1	000-255	0 - 100%		255
2	Red 1	000-255	0 - 100%		0
3	Green 1	000-255	0 - 100%		0
4	Blue 1	000-255	0 - 100%		0
5	Dimmer 2	000-255	0 - 100%		255
6	Red 2	000-255	0 - 100%		0
7	Green 2	000-255	0 - 100%		0
8	Blue 2	000-255	0 - 100%		0
9	Shutter 1+2	000 - 019	Shutter close		20
		020 - 024	Shutter open		
		025 - 064	Strobe 1 (fast ⊕ slow)		
		065 - 069	Shutter open		
		070 - 084	Strobe 2: opening pulse (fast ⊕ slow)		
		085 - 089	Shutter open		
		090 - 104	Strobe 3: closing pulse (fast ⊕ slow)		
		105 - 109	Shutter open		
		110 - 124	Strobe 4: random strobe (fast ⊕ slow)		
		125 - 129	Shutter open		
		130 - 144	Strobe 5: random opening pulse (fast ⊕ slow)		
		145 - 149	Shutter open		
		150 - 164	Strobe 6: random closing pulse (fast ⊕ slow)		
		165 - 169	Shutter open		
		170 - 184	Strobe 7: burst pulse (fast ⊕ slow)		
		185 - 189	Shutter open		
		190 - 204	Strobe 8: random burst pulse (fast ⊕ slow)		
		205 - 209	Shutter open		
		210 - 224	Strobe 9: sine wave (fast ⊕ slow)		
225 - 229	Shutter open				
230 - 244	Strobe 10: burst (fast ⊕ slow)				
245 - 255	Shutter open				
10	CTC (affects RGB 1+2)	000 - 004	5600K		0
		005-226	2000K-6500K linear in 20-21K steps (please see detailed CTC chart)		
		182-182	5600K	according to CTC chart	
		226-226	6500K		
		227-255	6621K-10.000K linear in 120-121K steps (please see detailed CTC chart)		
11	Device Settings (please see remark *1)	000-029	No function		0
		030-034	Display Backlight On (hold 3s)		
		035-039	Display Backlight Off (hold 3s)		
		040-044	No function		

11	Device Settings (please see remark *1)	045-049	DMX Fail Blackout (hold 3s)		0
		050-054	DMX Fail Hold (hold 3s)		
		055-059	DMX Fail - Emergency Light (hold 3s)		
		060-064	No function		
		065-069	Linear Dimmer Curve (hold 1,5s)		
		070-074	Exponential Dimmer Curve (hold 1,5s)		
		075-079	Logarithmic Dimmer Curve (hold 1,5s)		
		080-084	S-Curve Dimmer Curve (hold 1,5s)		
		085-089	No function		
		090-094	LED (Fast) Dimmer Response (hold 1,5s)		
		095-099	Medium Dimmer Response (hold 1,5s)		
		100-104	Halogen(Slow) Dimmer Response (hold 1,5s)		
		105-109	No function		
		110-114	Redshift On (hold 1,5s / affects only between 2700-3500K )		
		115-119	Redshift Off (hold 1,5s)		
		120-124	No function		
		125-129	Full Calibration (Colors & CCT / hold 3s)		
		130-134	CCT Calibration (RAW Colors / hold 3s)		
		135-139	No function		
		140-144	LED Frequency 800Hz (hold 3s)		
		145-149	LED Frequency 1200Hz (hold 3s)		
		150-154	LED Frequency 2000Hz (hold 3s)		
		155-159	LED Frequency 3600Hz (hold 3s)		
		160-164	LED Frequency 12kHz (hold 3s)		
		165-169	LED Frequency 25kHz (hold 3s)		
		170-174	No function		
		175-179	Fan Auto (hold 3s)		
		180-184	Fan Silent (hold 3s)		
		185-189	Fan Off (hold 3s)		
		190-194	Fan High Power (hold 3s)		
		195-199	No function		
		200-204	Invert Mapping Off (hold 3s)		
		205-209	Invert Mapping On (hold 3s)		
		210-214	No function		
215-219	LED Mode - Illumination (hold 1,5s)				
220-224	LED Mode - Boost (hold 1,5s)				
225-229	No function				
230-234	Factory Reset (hold 3s)				
235-239	User Reset (hold 3s)	no self-test by DMX			
240-255	No function				



**13CH STANDARD RGB (Calibrated / default)**

CH	Function	Value	Setting	Remark	Default
1	Master Dimmer	000-255	0 - 100%		0
2	Shutter	000 - 019	Shutter close		20
		020 - 024	Shutter open		
		025 - 064	Strobe 1 (fast ⊕ slow)		
		065 - 069	Shutter open		
		070 - 084	Strobe 2: opening pulse (fast ⊕ slow)		
		085 - 089	Shutter open		
		090 - 104	Strobe 3: closing pulse (fast ⊕ slow)		
		105 - 109	Shutter open		
		110 - 124	Strobe 4: random strobe (fast ⊕ slow)		
		125 - 129	Shutter open		
		130 - 144	Strobe 5: random opening pulse (fast ⊕ slow)		
2	Shutter	145 - 149	Shutter open		20
		150 - 164	Strobe 6: random closing pulse (fast ⊕ slow)		
		165 - 169	Shutter open		
		170 - 184	Strobe 7: burst pulse (fast ⊕ slow)		
		185 - 189	Shutter open		
		190 - 204	Strobe 8: random burst pulse (fast ⊕ slow)		
		205 - 209	Shutter open		
		210 - 224	Strobe 9: sine wave (fast ⊕ slow)		
		225 - 229	Shutter open		
		230 - 244	Strobe 10: burst (fast ⊕ slow)		
245 - 255	Shutter open				
3	Dimmer 1	000-255	0 - 100%		255
4	Red 1	000-255	0 - 100%		255
5	Green 1	000-255	0 - 100%		255
6	Blue 1	000-255	0 - 100%		255
7	Dimmer 2	000-255	0 - 100%		255
8	Red 2	000-255	0 - 100%		255
9	Green 2	000-255	0 - 100%		255
10	Blue 2	000-255	0 - 100%		255
11	CTC (affects RGB 1+2)	000 - 004	5600K	according to CTC chart	0
		005-182	2000K-6500K linear in 20-21K steps (please see detailed CTC chart)		
		182-225	5600K		
		226-226	6500K		
		227-255	6621K-10.000K linear in 120-121K steps (please see detailed CTC chart)		

12	Tint (affects CTC and RGB 1+2)	0	no function	0
		001-127	Magenta -> Neutral	
		128-128	Neutral	
		129-255	Neutral -> Green	
13	Device Settings (please see remark *1)	000-029	No function	0
		030-034	Display Backlight On (hold 3s)	
		035-039	Display Backlight Off (hold 3s)	
		040-044	No function	
		045-049	DMX Fail Blackout (hold 3s)	
		050-054	DMX Fail Hold (hold 3s)	
		055-059	DMX Fail - Emergency Light (hold 3s)	
		060-064	No function	
		065-069	Linear Dimmer Curve (hold 1,5s)	
		070-074	Exponential Dimmer Curve (hold 1,5s)	
		075-079	Logarithmic Dimmer Curve (hold 1,5s)	
		080-084	S-Curve Dimmer Curve (hold 1,5s)	
		085-089	No function	
		090-094	LED (Fast) Dimmer Response (hold 1,5s)	
		095-099	Medium Dimmer Response (hold 1,5s)	
		100-104	Halogen (Slow) Dimmer Response (hold 1,5s)	
105-109	No function			
110-114	Redshift On (hold 1,5s / affects only between 2700-3500K )			
115-119	Redshift Off (hold 1,5s)			
13	Device Settings (please see remark *1)	120-124	No function	0
		125-129	Full Calibration (Colors & CCT / hold 3s)	
		130-134	CCT Calibration(RAW Colors / hold 3s)	
		135-139	No function	
		140-144	LED Frequency 800Hz (hold 3s)	
		145-149	LED Frequency 1200Hz (hold 3s)	
		150-154	LED Frequency 2000Hz (hold 3s)	
		155-159	LED Frequency 3600Hz (hold 3s)	
		160-164	LED Frequency 12kHz (hold 3s)	
		165-169	LED Frequency 25kHz (hold 3s)	
		170-174	No function	
		175-179	Fan Auto (hold 3s)	
		180-184	Fan Silent (hold 3s)	
		185-189	Fan Off (hold 3s)	

13	Device Settings (please see remark *1)	190-194	Fan High Power (hold 3s)		0
		195-199	No function		
		200-204	Invert Mapping Off (hold 3s)		
		205-209	Invert Mapping On (hold 3s)		
		210-214	No function		
		215-219	LED Mode - Illumination (hold 1,5s)		
		220-224	LED Mode - Boost (hold 1,5s)		
		225-229	No function		
		230-234	Factory Reset (hold 3s)	Reset only starts if Shutter channel is set to DMX 250	
		235-239	User Reset (hold 3s)	Reset only starts if Shutter channel is set to DMX 250 / no self- test by DMX	
240-255	No function				

### 22CH STANDARD RGB (Calibrated)

CH	Function	Value	Setting	Remark	Default
1	Master Dimmer	000-255	0 - 100%		0
2	Master Dimmer Fine	000-255	0 - 100%		0
3	Shutter	000 - 019	Shutter close		20
		020 - 024	Shutter open		
		025 - 064	Strobe 1 (fast ⊕ slow)		
		065 - 069	Shutter open		
		070 - 084	Strobe 2: opening pulse (fast ⊕ slow)		
		085 - 089	Shutter open		
		090 - 104	Strobe 3: closing pulse (fast ⊕ slow)		
		105 - 109	Shutter open		
		110 - 124	Strobe 4: random strobe (fast ⊕ slow)		
		125 - 129	Shutter open		
		130 - 144	Strobe 5: random opening pulse (fast ⊕ slow)		
		145 - 149	Shutter open		
		150 - 164	Strobe 6: random closing pulse (fast ⊕ slow)		
		165 - 169	Shutter open		
3	Shutter	170 - 184	Strobe 7: burst pulse (fast ⊕ slow)		20
		185 - 189	Shutter open		
		190 - 204	Strobe 8: random burst pulse (fast ⊕ slow)		
		205 - 209	Shutter open		
		210 - 224	Strobe 9: sine wave (fast ⊕ slow)		
		225 - 229	Shutter open		
		230 - 244	Strobe 10: burst (fast ⊕ slow)		
245 - 255	Shutter open				
4	Dimmer 1	000-255	0 - 100%		255

5	Dimmer 1 Fine	000-255	0 - 100%		255
6	Red 1	000-255	0 - 100%		255
7	Red Fine 1	000-255	0 - 100%		255
8	Green 1	000-255	0 - 100%		255
9	Green Fine 1	000-255	0 - 100%		255
10	Blue 1	000-255	0 - 100%		255
11	Blue Fine 1	000-255	0 - 100%		255
12	Dimmer 2	000-255	0 - 100%		255
13	Dimmer 2 Fine	000-255	0 - 100%		255
14	Red 2	000-255	0 - 100%		255
15	Red Fine 2	000-255	0 - 100%		255
16	Green 2	000-255	0 - 100%		255
17	Green Fine 2	000-255	0 - 100%		255
18	Blue 2	000-255	0 - 100%		255
19	Blue Fine 2	000-255	0 - 100%		255
20	CTC (affects RGB 1+2)	000 - 004	5600K	according to CTC chart	0
		005-226	2000K-6500K linear in 20-21K steps (please see detailed CTC chart)		
		182-182	5600K		
		226-226	6500K		
		227-255	6621K-10.000K linear in 120-121K steps (please see detailed CTC chart)		
21	Tint (affects CTC and RGB 1+2)	0	no function		0
		001-127	Magenta -> Neutral		
		128-128	Neutral		
		129-255	Neutral -> Green		
22	Device Settings (please see remark *1)	000-029	No function		0
		030-034	Display Backlight On (hold 3s)		
		035-039	Display Backlight Off (hold 3s)		
		040-044	No function		
		045-049	DMX Fail Blackout (hold 3s)		
		050-054	DMX Fail Hold (hold 3s)		
		055-059	DMX Fail - Emergency Light (hold 3s)		
		060-064	No function		
		065-069	Linear Dimmer Curve (hold 1,5s)		
		070-074	Exponential Dimmer Curve (hold 1,5s)		
		075-079	Logarithmic Dimmer Curve (hold 1,5s)		
		080-084	S-Curve Dimmer Curve (hold 1,5s)		
		085-089	No function		
		090-094	LED (Fast) Dimmer Response (hold 1,5s)		

22	Device Settings (please see remark *1)	095-099	Medium Dimmer Response (hold 1,5s)		0
		100-104	Halogen (Slow) Dimmer Response (hold 1,5s)		
		105-109	No function		
		110-114	Redshift On (hold 1,5s / affects only between 2700-3500K )		
		115-119	Redshift Off (hold 1,5s)		
		120-124	No function		
		125-129	Full Calibration (Colors & CCT / hold 3s)		
		130-134	CCT Calibration(RAW Colors / hold 3s)		
		135-139	No function		
		140-144	LED Frequency 800Hz (hold 3s)		
		145-149	LED Frequency 1200Hz (hold 3s)		
		150-154	LED Frequency 2000Hz (hold 3s)		
		155-159	LED Frequency 3600Hz (hold 3s)		
		160-164	LED Frequency 12kHz (hold 3s)		
		165-169	LED Frequency 25kHz (hold 3s)		
		170-174	No function		
		175-179	Fan Auto (hold 3s)		
		180-184	Fan Silent (hold 3s)		
		185-189	Fan Off (hold 3s)		
		190-194	Fan High Power (hold 3s)		
		195-199	No function		
		200-204	Invert Mapping Off (hold 3s)		
		205-209	Invert Mapping On (hold 3s)		
		210-214	No function		
		215-219	LED Mode - Illumination (hold 1,5s)		
		220-224	LED Mode - Boost (hold 1,5s)		
		225-229	No function		
		230-234	Factory Reset (hold 3s)	Reset only starts if Shutter channel is set to DMX 250	
		235-239	User reset (hold 3s)	Reset only starts if Shutter channel is set to DMX 250 no self-test by DMX	
		240-255	No function		

**24CH EXTENDED RGB (Calibrated)**

CH	Function	Value	Setting	Remark	Default
1	Master Dimmer	000-255	0 - 100%		0
2	Shutter	000 - 019	Shutter close		20
		020 - 024	Shutter open		
		025 - 064	Strobe 1 (fast ⊕ slow)		
		065 - 069	Shutter open		
2	Shutter	070 - 084	Strobe 2: opening pulse (fast ⊕ slow)		20
		085 - 089	Shutter open		
		090 - 104	Strobe 3: closing pulse (fast ⊕ slow)		
		105 - 109	Shutter open		
2	Shutter	110 - 124	Strobe 4: random strobe (fast ⊕ slow)		20
		125 - 129	Shutter open		
		130 - 144	Strobe 5: random opening pulse (fast ⊕ slow)		
		145 - 149	Shutter open		
		150 - 164	Strobe 6: random closing pulse (fast ⊕ slow)		
		165 - 169	Shutter open		
		170 - 184	Strobe 7: burst pulse (fast ⊕ slow)		
		185 - 189	Shutter open		
		190 - 204	Strobe 8: random burst pulse (fast ⊕ slow)		
		205 - 209	Shutter open		
		210 - 224	Strobe 9:sine wave (fast ⊕ slow)		
		225 - 229	Shutter open		
		230 - 244	Strobe 10: burst (fast ⊕ slow)		
		245 - 255	Shutter open		
3	Duration	000-255	0 - 100% (0ms - 510ms)	only affects to channel 2 - Strobe 1 025-064	0
4	Dimmer 1	000-255	0 - 100%		255
5	Red 1	000-255	0 - 100%		255
6	Green 1	000-255	0 - 100%		255
7	Blue 1	000-255	0 - 100%		255
8	CTC 1 (affects RGB 1)	000 - 004	5600K	according to CTC chart	0
		005-226	2000K-6500K linear in 20-21K steps (please see detailed CTC chart)		
		182-182	5600K		
		226-226	6500K		
		227-255	6621K-10.000K linear in 120-121K steps (please see detailed CTC chart)		
9	Tint 1 (affects CTC 1 and RGB 1)	0	no function		0
		001-127	Magenta -> Neutral		
		128-128	Neutral		
		129-255	Neutral -> Green		

10	Color Macro 1 (override RGB 1/ CTC 1)		Please see ROXX color macro chart		0
11	Color Macro Cross-fade 1 (Transition Time between Color Macros 1)	000 - 005	no function		0
		006-105	0,1s - 10s (0,1s steps)		
		106-214	11s - 119s (1s steps)		
		215-244	2m - 4m50s (10s steps)		
		245-255	5m - 15m (1m steps)		
12	Dimmer 2	000-255	0 - 100%		255
13	Red 2	000-255	0 - 100%		255
14	Green 2	000-255	0 - 100%		255
15	Blue 2	000-255	0 - 100%		255
16	CTC 2 (affects RGB 2)	000 - 004	5600K	according to CTC chart	0
		005-226	2000K-6500K linear in 20-21K steps (please see detailed CTC chart)		
		182-182	5600K		
		226-226	6500K		
		227-255	6621K-10.000K linear in 120-121K steps (please see detailed CTC chart)		
17	Tint 2 (affects CTC 2 and RGB 2)	0	no function		0
		001-127	Magenta -> Neutral		
		128-128	Neutral		
		129-255	Neutral -> Green		
18	Color Macro 2 (override RGB 2 / CTC 2)		Please see ROXX color macro chart		
19	Color Macro Cross-fade 2 (Transition Time between Color Macros 2)	000 - 005	no function		0
		006-105	0,1s - 10s (0,1s steps)		
		106-214	11s - 119s (1s steps)		
		215-244	2m - 4m50s (10s steps)		
		245-255	5m - 15m (1m steps)		
20	Effect override RGB 1+2 / CTC 1+2, Color Macro 1+2	000-015	No Function		0
		016-039	Effect 1 (slow to fast)		
		040-063	Effect 2 (slow to fast)		
		064-87	Effect 3 (slow to fast)		
		88-111	Effect 4 (slow to fast)		
		112-135	Effect 5 (slow to fast)		
		136-159	Effect 6 (slow to fast)		
		160-183	Effect 7 (slow to fast)		
20	Effect override RGB 1+2 / CTC 1+2, Color Macro 1+2	184-207	Effect 8 (slow to fast)		0
		208-231	Effect 9 (slow to fast)		
		232-255	Effect 10 (slow to fast)		

21	Dimmer Curve	000-51	No Function - Current Preset from Menu Settings	0
		052-101	Linear Dimmer Curve	
		102-152	Exponential Dimmer Curve	
		153-203	Logarithmic Dimmer Curve	
		204-255	S-Curve Dimmer Curve	
22	Dimmer Response	000-063	No Function - Current Preset from Menu Settings	0
		064-127	LED / fast	
		128-191	Medium	
		192-255	Halogen / slow	
23	Redshift	000-84	No Function - Current Preset from Menu Settings	0
		085-170	Redshift Off	
		171-255	Redshift On	
24	Device Settings (please see remark *1)	000-029	No function	0
		030-034	Display Backlight On (hold 3s)	
		035-039	Display Backlight Off (hold 3s)	
		040-044	No function	
		045-049	DMX Fail Blackout (hold 3s)	
		050-054	DMX Fail Hold (hold 3s)	
		055-059	DMX Fail - Emergency Light (hold 3s)	
		060-124	No function	
		125-129	Full Calibration (Colors & CCT / hold 3s)	
		130-134	CCT Calibration( RAW Colors / hold 3s)	
		135-139	No function	
		140-144	LED Frequency 800Hz (hold 3s)	
		145-149	LED Frequency 1200Hz (hold 3s)	
		150-154	LED Frequency 2000Hz (hold 3s)	
		155-159	LED Frequency 3600Hz (hold 3s)	
		160-164	LED Frequency 12kHz (hold 3s)	
		165-169	LED Frequency 25kHz (hold 3s)	
		170-174	No function	
		175-179	Fan Auto (hold 3s)	
		180-184	Fan Silent (hold 3s)	
		185-189	Fan Off (hold 3s)	
		190-194	Fan High Power (hold 3s)	
		195-199	No function	
		200-204	Invert Mapping Off (hold 3s)	
		205-209	Invert Mapping On (hold 3s)	
		210-214	No function	
215-219	LED Mode - Illumination (hold 1,5s)			
220-224	LED Mode - Boost (hold 1,5s)			



24	Device Settings (please see remark *1)	225-229	No function		0
		230-234	Factory Reset (hold 3s)	Reset only starts if Shutter channel is set to DMX 250	
		235-239	User Reset (hold 3s)	Reset only starts if Shutter channel is set to DMX 250 / no self- test by DMX	
		240-255	No function		

### 33 CH EXTENDED RGB (Calibrated )

CH	Function	Value	Setting	Remark	Default
1	Master Dimmer	000-255	0 - 100%		0
2	Master Dimmer Fine	000-255	0 - 100%		0
3	Shutter	000 - 019	Shutter close		20
		020 - 024	Shutter open		
		025 - 064	Strobe 1 (fast ⊕ slow)		
		065 - 069	Shutter open		
		070 - 084	Strobe 2: opening pulse (fast ⊕ slow)		
		085 - 089	Shutter open		
		090 - 104	Strobe 3: closing pulse (fast ⊕ slow)		
		105 - 109	Shutter open		
		110 - 124	Strobe 4: random strobe (fast ⊕ slow)		
		125 - 129	Shutter open		
		130 - 144	Strobe 5: random opening pulse (fast ⊕ slow)		
		145 - 149	Shutter open		
		150 - 164	Strobe 6: random closing pulse (fast ⊕ slow)		
		165 - 169	Shutter open		
		170 - 184	Strobe 7: burst pulse (fast ⊕ slow)		
		185 - 189	Shutter open		
		190 - 204	Strobe 8: random burst pulse (fast ⊕ slow)		
		205 - 209	Shutter open		
		210 - 224	Strobe 9: sine wave (fast ⊕ slow)		
225 - 229	Shutter open				
230 - 244	Strobe 10: burst (fast ⊕ slow)				
245 - 255	Shutter open				
4	Duration	000-255	0 - 100% (0ms - 510ms)	only affects to channel 2 - Strobe 1 025-064	0
5	Dimmer 1	000-255	0 - 100%		255
6	Dimmer 1 Fine	000-255	0 - 100%		255
7	Red 1	000-255	0 - 100%		255
8	Red Fine 1	000-255	0 - 100%		255
9	Green 1	000-255	0 - 100%		255

10	Green Fine 1	000-255	0 - 100%		255
11	Blue 1	000-255	0 - 100%		255
12	Blue Fine 1	000-255	0 - 100%		255
13	CTC 1 (affects RGB 1)	000 - 004	5600K	according to CTC chart	0
		005-226	2000K-6500K linear in 20-21K steps (please see detailed CTC chart)		
		182-182	5600K		
		226-226	6500K		
		227-255	6621K-10.000K linear in 120-121K steps (please see detailed CTC chart)		
14	Tint 1 (affects CTC 1 and RGB 1)	0	no function		0
		001-127	Magenta -> Neutral		
		128-128	Neutral		
		129-255	Neutral -> Green		
15	Color Macro 1 (override RGB 1/ CTC 1)		Please see ROXX color macro chart		0
16	Color Macro Cross- fade 1 (Transition Time between Color Macros 1)	000 - 005	no function		0
		006-105	0,1s - 10s (0,1s steps)		
		106-214	11s - 119s (1s steps)		
		215-244	2m - 4m50s (10s steps)		
		245-255	5m - 15m (1m steps)		
17	Dimmer 2	000-255	0 - 100%		255
18	Dimmer 2 Fine	000-255	0 - 100%		255
19	Red 2	000-255	0 - 100%		255
20	Red Fine 2	000-255	0 - 100%		255
21	Green 2	000-255	0 - 100%		255
22	Green Fine 2	000-255	0 - 100%		255
23	Blue 2	000-255	0 - 100%		255
24	Blue Fine 2	000-255	0 - 100%		255
25	CTC 2 (affects RGB 2)	000 - 004	5600K	according to CTC chart	0
		005-226	2000K-6500K linear in 20-21K steps (please see detailed CTC chart)		
		182-182	5600K		
		226-226	6500K		
		227-255	6621K-10.000K linear in 120-121K steps (please see detailed CTC chart)		
26	Tint 2 (affects CTC 2 and RGB 2)	0	no function		0
		001-127	Magenta -> Neutral		
		128-128	Neutral		
		129-255	Neutral -> Green		
27	Color Macro 2 (override RGB 2/ CTC 2)		Please see ROXX color macro chart		0

28	Color Macro Cross-fade 2 (Transition Time between Color Macros 2)	000 - 005	no function		0
		006-105	0,1s - 10s (0,1s steps)		
		106-214	11s - 119s (1s steps)		
		215-244	2m - 4m50s (10s steps)		
		245-255	5m - 15m (1m steps)		
29	Effect override RGB 1+2 / CTC 1+2, Color Macro 1+2	000-15	No Function		0
		016-039	Effect 1 (slow to fast)		
		040-063	Effect 2 (slow to fast)		
		064-87	Effect 3 (slow to fast)		
		88-111	Effect 4 (slow to fast)		
		112-135	Effect 5 (slow to fast)		
		136-159	Effect 6 (slow to fast)		
		160-183	Effect 7 (slow to fast)		
		184-207	Effect 8 (slow to fast)		
		208-231	Effect 9 (slow to fast)		
		232-255	Effect 10 (slow to fast)		
30	Dimmer Curve	000-51	No Function - Current Preset from Menu Settings		0
		052-101	Linear Dimmer Curve		
		102-152	Exponential Dimmer Curve		
		153-203	Logarithmic Dimmer Curve		
		204-255	S-Curve Dimmer Curve		
31	Dimmer Response	000-063	No Function - Current Preset from Menu Settings		0
		064-127	LED / fast		
		128-191	Medium		
		192-255	Halogen / slow		
32	Redshift	000-84	No Function - Current Preset from Menu Settings	Redshift affects only between CCT 2700-3500K.	0
		085-170	Redshift Off		
		171-255	Redshift On		

33	Device Settings (please see remark *1)	000-029	No function		0
		030-034	Display Backlight On (hold 3s)		
		035-039	Display Backlight Off (hold 3s)		
		040-044	No function		
		045-049	DMX Fail Blackout (hold 3s)		
		050-054	DMX Fail Hold (hold 3s)		
		055-059	DMX Fail - Emergency Light (hold 3s)		
		060-124	No function		
		125-129	Full Calibration (Colors & CCT / hold 3s)		
		130-134	CCT Calibration (RAW Colors / hold 3s)		
		135-139	No function		
		140-144	LED Frequency 800Hz (hold 3s)		
		145-149	LED Frequency 1200Hz (hold 3s)		
		150-154	LED Frequency 2000Hz (hold 3s)		
		155-159	LED Frequency 3600Hz (hold 3s)		
		160-164	LED Frequency 12kHz (hold 3s)		
		165-169	LED Frequency 25kHz (hold 3s)		
		170-174	No function		
		175-179	Fan Auto (hold 3s)		
		180-184	Fan Silent (hold 3s)		
		185-189	Fan Off (hold 3s)		
		190-194	Fan High Power (hold 3s)		
		195-199	No function		
		200-204	Invert Mapping Off (hold 3s)		
		205-209	Invert Mapping On (hold 3s)		
		210-214	No function		
		215-219	LED Mode - Illumination (hold 1,5s)		
		220-224	LED Mode - Boost (hold 1,5s)		
		225-229	No function		
		230-234	Factory Reset (hold 3s)	Reset only starts if Shutter channel is set to DMX 250	
		235-239	User Reset (hold 3s)	Reset only starts if Shutter channel is set to DMX 250 / no self- test by DMX	
		240-255	No function		

#### 10CH DIRECT (RAW)

CH	Function	Value	Setting	Remark	Default
1	Red 1	000-255	0 - 100%		0
2	Green 1	000-255	0 - 100%		0
3	Blue 1	000-255	0 - 100%		0

4	Amber 1	000-255	0 - 100%		0
5	White 1	000-255	0 - 100%		0
6	Red 2	000-255	0 - 100%		0
7	Green 2	000-255	0 - 100%		0
8	Blue 2	000-255	0 - 100%		0
9	Amber 2	000-255	0 - 100%		0
10	White 2	000-255	0 - 100%		0

### 12CH DIRECT (RAW)

CH	Function	Value	Setting	Remark	Default
1	Master Dimmer	000-255	0 - 100%		0
2	Shutter	000 - 019	Shutter close		20
		020 - 024	Shutter open		
		025 - 064	Strobe 1 (fast ⊕ slow)		
		065 - 069	Shutter open		
		070 - 084	Strobe 2: opening pulse (fast ⊕ slow)		
		085 - 089	Shutter open		
		090 - 104	Strobe 3: closing pulse (fast ⊕ slow)		
		105 - 109	Shutter open		
2	Shutter	110 - 124	Strobe 4: random strobe (fast ⊕ slow)		20
		125 - 129	Shutter open		
		130 - 144	Strobe 5: random opening pulse (fast ⊕ slow)		
		145 - 149	Shutter open		
		150 - 164	Strobe 6: random closing pulse (fast ⊕ slow)		
		165 - 169	Shutter open		
		170 - 184	Strobe 7: burst pulse (fast ⊕ slow)		
		185 - 189	Shutter open		
		190 - 204	Strobe 8: random burst pulse (fast ⊕ slow)		
		205 - 209	Shutter open		
		210 - 224	Strobe 9: sine wave (fast ⊕ slow)		
		225 - 229	Shutter open		
		230 - 244	Strobe 10: burst (fast ⊕ slow)		
		245 - 255	Shutter open		
3	Red	000-255	0 - 100%		255
4	Green	000-255	0 - 100%		255
5	Blue	000-255	0 - 100%		255
6	Amber	000-255	0 - 100%		255
7	White	000-255	0 - 100%		255

8	CTC (affects RGBAW)	000 - 004	5600K	according to CTC chart	0
		005-226	2000K-6500K linear in 20-21K steps (please see detailed CTC chart)		
		182-182	5600K		
		226-226	6500K		
		227-255	6621K-10.000K linear in 120-121K steps (please see detailed CTC chart)		
9	Tint (affects CTC and RGBAW)	0	no function		0
		001-127	Magenta -> Neutral		
		128-128	Neutral		
		129-255	Neutral -> Green		
10	Color Macro (override RGBAW/ CTC)		Please see ROXX color macro chart		0
11	Color Macro Cross- fade (Transition Time between Color Macros)	000 - 005	no function		0
		006-105	0,1s - 10s (0,1s steps)		
		106-214	11s - 119s (1s steps)		
		215-244	2m - 4m50s (10s steps)		
		245-255	5m - 15m (1m steps)		
12	Device Settings (please see remark *1)	000-029	No function		0
		030-034	Display Backlight On (hold 3s)		
		035-039	Display Backlight Off (hold 3s)		
		040-044	No function		
		045-049	DMX Fail Blackout (hold 3s)		
		050-054	DMX Fail Hold (hold 3s)		
		055-059	DMX Fail - Emergency Light (hold 3s)		
		060-064	No function		
		065-069	Linear Dimmer Curve (hold 1,5s)		
		070-074	Exponential Dimmer Curve (hold 1,5s)		
		075-079	Logarithmic Dimmer Curve (hold 1,5s)		
		080-084	S-Curve Dimmer Curve (hold 1,5s)		
		085-089	No function		
		090-094	LED (Fast) Dimmer Response (hold 1,5s)		
		095-099	Medium Dimmer Response (hold 1,5s)		
		100-104	Halogen (Slow) Dimmer Response (hold 1,5s)		
		105-109	No function		
110-114	Redshift On (hold 1,5s / affects only bet- ween 2700-3500K )				
115-119	Redshift Off (hold 1,5s)				

12	Device Settings (please see remark *1)	120-124	No function		0
		125-129	RAW (hold 3s)		
		130-134	User Calibration (hold 3s)		
		135-139	No function		
		140-144	LED Frequency 800Hz (hold 3s)		
		145-149	LED Frequency 1200Hz (hold 3s)		
		150-154	LED Frequency 2000Hz (hold 3s)		
		155-159	LED Frequency 3600Hz (hold 3s)		
		160-164	LED Frequency 12kHz (hold 3s)		
		165-169	LED Frequency 25kHz (hold 3s)		
		170-174	No function		
		175-179	Fan Auto (hold 3s)		
		180-184	Fan Silent (hold 3s)		
		185-189	Fan Off (hold 3s)		
		190-194	Fan High Power (hold 3s)		
		195-199	No function		
		200-204	Invert Mapping Off (hold 3s)		
		205-209	Invert Mapping On (hold 3s)		
		210-214	No function		
		215-219	LED Mode - Illumination (hold 1,5s)		
		220-224	LED Mode - Boost (hold 1,5s)		
		225-229	No function		
		230-234	Factory Reset (hold 3s)	Reset only starts if Shutter channel is set to DMX 250	
		235-239	User Reset (hold 3s)	Reset only starts if Shutter channel is set to DMX 250 / no self- test by DMX	
240-255	No function				

### 17CH DIRECT (RAW)

CH	Function	Value	Setting	Remark	Default
1	Master Dimmer	000-255	0 - 100%		0
2	Shutter	000 - 019	Shutter close		20
		020 - 024	Shutter open		
		025 - 064	Strobe 1 (fast ⊕ slow)		
		065 - 069	Shutter open		
		070 - 084	Strobe 2: opening pulse (fast ⊕ slow)		
		085 - 089	Shutter open		
		090 - 104	Strobe 3: closing pulse (fast ⊕ slow)		
		105 - 109	Shutter open		
		110 - 124	Strobe 4: random strobe (fast ⊕ slow)		
		125 - 129	Shutter open		

2	Shutter	130 - 144	Strobe 5: random opening pulse (fast @ slow)	20	
		145 - 149	Shutter open		
		150 - 164	Strobe 6: random closing pulse (fast @ slow)		
		165 - 169	Shutter open		
		170 - 184	Strobe 7: burst pulse (fast @ slow)		
		185 - 189	Shutter open		
		190 - 204	Strobe 8: random burst pulse (fast @ slow)		
		205 - 209	Shutter open		
		210 - 224	Strobe 9: sine wave (fast @ slow)		
		225 - 229	Shutter open		
		230 - 244	Strobe 10: burst (fast @ slow)		
		245 - 255	Shutter open		
3	Dimmer 1	000-255	0 - 100%	255	
4	Red 1	000-255	0 - 100%	255	
5	Green 1	000-255	0 - 100%	255	
6	Blue 1	000-255	0 - 100%	255	
7	Amber 1	000-255	0 - 100%	255	
8	White 1	000-255	0 - 100%	255	
9	Dimmer 2	000-255	0 - 100%	255	
10	Red 2	000-255	0 - 100%	255	
11	Green 2	000-255	0 - 100%	255	
12	Blue 2	000-255	0 - 100%	255	
13	Amber 2	000-255	0 - 100%	255	
14	White 2	000-255	0 - 100%	255	
15	CTC (affects RGBAW 1+2)	000 - 004	5600K	according to CTC chart	0
		005-226	2000K-6500K linear in 20-21K steps (please see detailed CTC chart)		
		182-182	5600K		
15	CTC (affects RGBAW 1+2)	226-226	6500K		0
		227-255	6621K-10.000K linear in 120-121K steps (please see detailed CTC chart)		
16	Tint (affects CTC and RGBAW 1+2)	0	no function		0
		001-127	Magenta -> Neutral		
		128-128	Neutral		
		129-255	Neutral -> Green		
17	Device Settings (please see remark *1)	000-029	No function		0
		030-034	Display Backlight On (hold 3s)		
		035-039	Display Backlight Off (hold 3s)		
		040-044	No function		
		045-049	DMX Fail Blackout (hold 3s)		
		050-054	DMX Fail Hold (hold 3s)		



17	Device Settings (please see remark *1)	055-059	DMX Fail - Emergency Light (hold 3s)		0
		060-064	No function		
		065-069	Linear Dimmer Curve (hold 1,5s)		
		070-074	Exponential Dimmer Curve (hold 1,5s)		
		075-079	Logarithmic Dimmer Curve (hold 1,5s)		
		080-084	S-Curve Dimmer Curve (hold 1,5s)		
		085-089	No function		
		090-094	LED (Fast) Dimmer Response (hold 1,5s)		
		095-099	Medium Dimmer Response (hold 1,5s)		
		100-104	Halogen (Slow) Dimmer Response (hold 1,5s)		
		105-109	No function		
		110-114	Redshift On (hold 1,5s / affects only bet- ween 2700-3500K)		
		115-119	Redshift Off (hold 1,5s)		
		120-124	No function		
		125-129	RAW (hold 3s)		
		130-134	User Calibration (hold 3s)		
		135-139	No function		
		140-144	LED Frequency 800Hz (hold 3s)		
		145-149	LED Frequency 1200Hz (hold 3s)		
		150-154	LED Frequency 2000Hz (hold 3s)		
		155-159	LED Frequency 3600Hz (hold 3s)		
		160-164	LED Frequency 12kHz (hold 3s)		
		165-169	LED Frequency 25kHz (hold 3s)		
		170-174	No function		
		175-179	Fan Auto (hold 3s)		
		180-184	Fan Silent (hold 3s)		
		185-189	Fan Off (hold 3s)		
		190-194	Fan High Power (hold 3s)		
		195-199	No function		
		200-204	Invert Mapping Off (hold 3s)		
		205-209	Invert Mapping On (hold 3s)		
		210-214	No function		
		215-219	LED Mode - Illumination (hold 1,5s)		
220-224	LED Mode - Boost (hold 1,5s)				
225-229	No function				
230-234	Factory Reset (hold 3s)	Reset only starts if Shutter channel is set to DMX 250			
235-239	User Reset (hold 3s)	Reset only starts if Shutter channel is set to DMX 250 / no self- test by DMX			
240-255	No function				

**28CH DIRECT (RAW)**

CH	Function	Value	Setting	Remark	Default
1	Master Dimmer	000-255	0 - 100%		0
2	Shutter	000 - 019	Shutter close		20
		020 - 024	Shutter open		
		025 - 064	Strobe 1 (fast ⊕ slow)		
		065 - 069	Shutter open		
		070 - 084	Strobe 2: opening pulse (fast ⊕ slow)		
		085 - 089	Shutter open		
		090 - 104	Strobe 3: closing pulse (fast ⊕ slow)		
		105 - 109	Shutter open		
		110 - 124	Strobe 4: random strobe (fast ⊕ slow)		
		125 - 129	Shutter open		
		130 - 144	Strobe 5: random opening pulse (fast ⊕ slow)		
		145 - 149	Shutter open		
		150 - 164	Strobe 6: random closing pulse (fast ⊕ slow)		
		165 - 169	Shutter open		
2	Shutter	170 - 184	Strobe 7: burst pulse (fast ⊕ slow)		20
		185 - 189	Shutter open		
		190 - 204	Strobe 8: random burst pulse (fast ⊕ slow)		
		205 - 209	Shutter open		
		210 - 224	Strobe 9: sine wave (fast ⊕ slow)		
		225 - 229	Shutter open		
2	Shutter	230 - 244	Strobe 10: burst (fast ⊕ slow)		20
		245 - 255	Shutter open		
3	Duration	000-255	0 - 100% (0ms - 510ms)	only affects to channel 2 - Strobe 1 025-064	0
4	Dimmer 1	000-255	0 - 100%		255
5	Red 1	000-255	0 - 100%		255
6	Green 1	000-255	0 - 100%		255
7	Blue 1	000-255	0 - 100%		255
8	Amber 1	000-255	0 - 100%		255
9	White 1	000-255	0 - 100%		255

10	CTC 1 (affects RGBAW 1)	000 - 004	5600K	according to CTC chart	0
		005-226	2000K-6500K linear in 20-21K steps (please see detailed CTC chart)		
		182-182	5600K		
		226-226	6500K		
		227-255	6621K-10.000K linear in 120-121K steps (please see detailed CTC chart)		
11	Tint 1 (affects CTC 1 and RGBAW 1)	0	no function		0
		001-127	Magenta -> Neutral		
		128-128	Neutral		
		129-255	Neutral -> Green		
12	Color Macro 1 (override RGBAW 1/ CTC 1)		Please see ROXX color macro chart		0
13	Color Macro Crossfade 1 (Transition Time between Color Macros 1)	000 - 005	no function		0
		006-105	0,1s - 10s (0,1s steps)		
		106-214	11s - 119s (1s steps)		
		215-244	2m - 4m50s (10s steps)		
		245-255	5m - 15m (1m steps)		
14	Dimmer 2	000-255	0 - 100%		255
15	Red 2	000-255	0 - 100%		255
16	Green 2	000-255	0 - 100%		255
17	Blue 2	000-255	0 - 100%		255
18	Amber 2	000-255	0 - 100%		255
19	White 2	000-255	0 - 100%		255
20	CTC 2 (affects RGBAW 2)	000 - 004	5600K	according to CTC chart	0
		005-226	2000K-6500K linear in 20-21K steps (please see detailed CTC chart)		
		182-182	5600K		
		226-226	6500K		
		227-255	6621K-10.000K linear in 120-121K steps (please see detailed CTC chart)		
21	Tint 2 (affects CTC 2 and RGBAW 2)	0	no function		0
		001-127	Magenta -> Neutral		
		128-128	Neutral		
		129-255	Neutral -> Green		
22	Color Macro 2 (override RGBAW 2 / CTC 2)		Please see ROXX color macro chart		0
23	Color Macro Cross- fade 2 (Transition Time between Color Macros 2)	000 - 005	no function		0
		006-105	0,1s - 10s (0,1s steps)		
		106-214	11s - 119s (1s steps)		
		215-244	2m - 4m50s (10s steps)		
		245-255	5m - 15m (1m steps)		

24	Effect override RGBAW 1+2 / CTC 1+2, Color Macro 1+2	000-15	No Function		0
		016-039	Effect 1 (slow to fast)		
		040-063	Effect 2 (slow to fast)		
		064-87	Effect 3 (slow to fast)		
		88-111	Effect 4 (slow to fast)		
		112-135	Effect 5 (slow to fast)		
		136-159	Effect 6 (slow to fast)		
		160-183	Effect 7 (slow to fast)		
		184-207	Effect 8 (slow to fast)		
		208-231	Effect 9 (slow to fast)		
		232-255	Effect 10 (slow to fast)		
25	Dimmer Curve	000-51	No Function - Current Preset from Menu Settings		0
		052-101	Linear Dimmer Curve		
		102-152	Exponential Dimmer Curve		
		153-203	Logarithmic Dimmer Curve		
		204-255	S-Curve Dimmer Curve		
26	Dimmer Response	000-063	No Function - Current Preset from Menu Settings		0
		064-127	LED / fast		
		128-191	Medium		
		192-255	Halogen / slow		
27	Redshift	000-84	No Function - Current Preset from Menu Settings	Redshift affects only between CCT 2700-3500K.	0
		085-170	Redshift Off		
		171-255	Redshift On		
28	Device Settings (please see remark *1)	000-029	No function		0
		030-034	Display Backlight On (hold 3s)		
		035-039	Display Backlight Off (hold 3s)		
		040-044	No function		
		045-049	DMX Fail Blackout (hold 3s)		
		050-054	DMX Fail Hold (hold 3s)		
		055-059	DMX Fail - Emergency Light (hold 3s)		
		060-122	No function		
		123-127	RAW Mode (hold 3s)		
		128-132	User Calibration (hold 3s)		

28	Device Settings (please see remark *1)	133-139	No function		0
		140-144	LED Frequency 800Hz (hold 3s)		
		145-149	LED Frequency 1200Hz (hold 3s)		
		150-154	LED Frequency 2000Hz (hold 3s)		
		155-159	LED Frequency 3600Hz (hold 3s)		
		160-164	LED Frequency 12kHz (hold 3s)		
		165-169	LED Frequency 25kHz (hold 3s)		
		170-174	No function		
		175-179	Fan Auto (hold 3s)		
		180-184	Fan Silent (hold 3s)		
		185-189	Fan Off (hold 3s)		
		190-194	Fan High Power (hold 3s)		
		195-199	No function		
		200-204	Invert Mapping Off (hold 3s)		
		205-209	Invert Mapping On (hold 3s)		
		210-214	No function		
		215-219	LED Mode - Illumination (hold 1,5s)		
		220-224	LED Mode - Boost (hold 1,5s)		
		225-229	No function		
		230-234	Factory Reset (hold 3s)	Reset only starts if Shutter channel is set to DMX 250	
235-239	User Reset (hold 3s)	Reset only starts if Shutter channel is set to DMX 250 / no self- test by DMX			
240-255	No function				

**41CH DIRECT (RAW)**

CH	Function	Value	Setting	Remark	Default
1	Master Dimmer	000-255	0 - 100%		0
2	Master Dimmer Fine	000-255	0 - 100%		0
3	Shutter	000 - 019	Shutter close		20
		020 - 024	Shutter open		
		025 - 064	Strobe 1 (fast ⊕ slow)		
		065 - 069	Shutter open		
		070 - 084	Strobe 2: opening pulse (fast ⊕ slow)		
		085 - 089	Shutter open		
		090 - 104	Strobe 3: closing pulse (fast ⊕ slow)		
		105 - 109	Shutter open		
		110 - 124	Strobe 4: random strobe (fast ⊕ slow)		
		125 - 129	Shutter open		
3	Shutter	130 - 144	Strobe 5: random opening pulse (fast ⊕ slow)		20
		145 - 149	Shutter open		
		150 - 164	Strobe 6: random closing pulse (fast ⊕ slow)		
		165 - 169	Shutter open		
		170 - 184	Strobe 7: burst pulse (fast ⊕ slow)		
		185 - 189	Shutter open		
		190 - 204	Strobe 8: random burst pulse (fast ⊕ slow)		
		205 - 209	Shutter open		
		210 - 224	Strobe 9: sine wave (fast ⊕ slow)		
		225 - 229	Shutter open		
4	Duration	230 - 244	Strobe 10: burst (fast ⊕ slow)		0
		245 - 255	Shutter open		
				only affects to channel 2 - Strobe 1 025-064	
5	Dimmer 1	000-255	0 - 100%		255
6	Dimmer 1 Fine	000-255	0 - 100%		255
7	Red 1	000-255	0 - 100%		255
8	Red Fine 1	000-255	0 - 100%		255
9	Green 1	000-255	0 - 100%		255
10	Green Fine 1	000-255	0 - 100%		255
11	Blue 1	000-255	0 - 100%		255
12	Blue Fine 1	000-255	0 - 100%		255
13	Amber 1	000-255	0 - 100%		255
14	Amber Fine 1	000-255	0 - 100%		255
15	White 1	000-255	0 - 100%		255
16	White Fine 1	000-255	0 - 100%		255

17	CTC 1 (affects RGBAW 1)	000 - 004	5600K	according to CTC chart	0
		005-226	2000K-6500K linear in 20-21K steps (please see detailed CTC chart)		
		182-182	5600K		
		226-226	6500K		
		227-255	6621K-10.000K linear in 120-121K steps (please see detailed CTC chart)		
18	Tint 1 (affects CTC 1 and RGBAW 1)	0	no function		0
		001-127	Magenta -> Neutral		
		128-128	Neutral		
		129-255	Neutral -> Green		
19	Color Macro 1 (override RGBAW 1/ CTC 1)		Please see ROXX color macro chart		0
20	Color Macro Cross- fade 1 (Transition Time between Color Macros 1)	000 - 005	no function		0
		006-105	0,1s - 10s (0,1s steps)		
		106-214	11s - 119s (1s steps)		
		215-244	2m - 4m50s (10s steps)		
		245-255	5m - 15m (1m steps)		
21	Dimmer 2	000-255	0 - 100%		255
22	Dimmer 2 Fine	000-255	0 - 100%		255
23	Red 2	000-255	0 - 100%		255
24	Red Fine 2	000-255	0 - 100%		255
25	Green 2	000-255	0 - 100%		255
26	Green Fine 2	000-255	0 - 100%		255
27	Blue 2	000-255	0 - 100%		255
28	Blue Fine 2	000-255	0 - 100%		255
29	Amber 2	000-255	0 - 100%		255
30	Amber Fine 2	000-255	0 - 100%		255
31	White 2	000-255	0 - 100%		255
32	White Fine 2	000-255	0 - 100%		255
33	CTC 2 (affects RGBAW 2)	000 - 004	5600K	according to CTC chart	0
		005-226	2000K-6500K linear in 20-21K steps (please see detailed CTC chart)		
		182-182	5600K		
		226-226	6500K		
		227-255	6621K-10.000K linear in 120-121K steps (please see detailed CTC chart)		
34	Tint 2 (affects CTC 2 and RGBAW 2)	0	no function		0
		001-127	Magenta -> Neutral		
		128-128	Neutral		
		129-255	Neutral -> Green		
35	Color Macro 2 (override RGBAW 2 / CTC 2)		Please see ROXX color macro chart		0

36	Color Macro Cross-fade 2 (Transition Time between Color Macros 2)	000 - 005	no function		0
		006-105	0,1s - 10s (0,1s steps)		
		106-214	11s - 119s (1s steps)		
		215-244	2m - 4m50s (10s steps)		
		245-255	5m - 15m (1m steps)		
37	Effect override RGBAW 1-4 / CTC 1-4, Color Macro 1-4	000-15	No Function		0
		016-039	Effect 1 (slow to fast)		
		040-063	Effect 2 (slow to fast)		
		064-87	Effect 3 (slow to fast)		
		88-111	Effect 4 (slow to fast)		
		112-135	Effect 5 (slow to fast)		
37	Effect override RGBAW 1-4 / CTC 1-4, Color Macro 1-4	136-159	Effect 6 (slow to fast)		0
		160-183	Effect 7 (slow to fast)		
		184-207	Effect 8 (slow to fast)		
		208-231	Effect 9 (slow to fast)		
		232-255	Effect 10 (slow to fast)		
38	Dimmer Curve	000-51	No Function - Current Preset from Menu Settings		0
		052-101	Linear Dimmer Curve		
		102-152	Exponential Dimmer Curve		
		153-203	Logarithmic Dimmer Curve		
		204-255	S-Curve Dimmer Curve		
39	Dimmer Response	000-063	No Function - Current Preset from Menu Settings		0
		064-127	LED / fast		
		128-191	Medium		
		192-255	Halogen / slow		
40	Redshift	000-84	No Function - Current Preset from Menu Settings	Redshift affects only between CCT 2700-3500K.	0
		085-170	Redshift Off		
		171-255	Redshift On		
41	Device Settings (please see remark *1)	000-029	No function		0
		030-034	Display Backlight On (hold 3s)		
		035-039	Display Backlight Off (hold 3s)		
		040-044	No function		
		045-049	DMX Fail Blackout (hold 3s)		
		050-054	DMX Fail Hold (hold 3s)		
		055-059	DMX Fail - Emergency Light (hold 3s)		
		060-122	No function		
		123-127	RAW Mode (hold 3s)		
		128-132	User Calibration (hold 3s)		
		133-139	No function		



Device Settings (please see remark *1)	140-144	LED Frequency 800Hz (hold 3s)	
	145-149	LED Frequency 1200Hz (hold 3s)	
	150-154	LED Frequency 2000Hz (hold 3s)	
	155-159	LED Frequency 3600Hz (hold 3s)	
	160-164	LED Frequency 12kHz (hold 3s)	
	165-169	LED Frequency 25kHz (hold 3s)	
	170-174	No function	
	175-179	Fan Auto (hold 3s)	
	180-184	Fan Silent (hold 3s)	
	185-189	Fan Off (hold 3s)	
	190-194	Fan High Power (hold 3s)	
	195-199	No function	
	200-204	Invert Mapping Off (hold 3s)	
	205-209	Invert Mapping On (hold 3s)	
	210-214	No function	
	215-219	LED Mode - Illumination (hold 1,5s)	
	220-224	LED Mode - Boost (hold 1,5s)	
	225-229	No function	
	230-234	Factory Reset (hold 3s)	Reset only starts if Shutter channel is set to DMX 250
	235-239	User Reset (hold 3s)	Reset only starts if Shutter channel is set to DMX 250 / no self- test by DMX
240-255	No function		
remark *1	After adjustments please set the value back to 000 to avoid any disturbance by endless function call.		

## Color Macro Chart for DMX

Gels - Color Macros for DMX		
DMX value	Gel Name	Color Number
000-005	no function	
006-008	Red	100% Red LED
009-011	Fire	LEE 019
012-014	Medium Red	LEE 027
015-017	Primary Red	LEE 106
018-020	Med Amber	LEE 020
021-023	Dark Amber	LEE 022
024-026	Deep Amber	LEE 104
027-029	Orange	LEE 105
030-032	Deep Golden Amber	LEE 135
033-035	Yellow	LEE 101
036-038	Green	100% Green LED
039-041	Lime Green	LEE 088
042-044	Moss Green	LEE 089
045-047	LEE Green	LEE 121
048-050	Primary Green	LEE 139
051-053	Jas Green	LEE 738
054-056	Jade	LEE 323
057-059	Blue	100% Blue LED
060-062	Sky Blue	LEE 068
063-065	Tokyo Blue	LEE 071
066-068	Light Blue	LEE 118
069-071	Marine Blue	LEE 131
072-074	Med Blue	LEE 132
075-077	Congo Blue	LEE 181
078-080	Mikkel Blue	LEE 716
081-083	Rose Pink	LEE 002
084-086	Med Pink	LEE 036
087-089	Light Lavender	LEE 052
090-092	Lavender	LEE 058

Gels - Color Macros for DMX		
093-095	Magenta	LEE 113
096-098	Mauve	LEE 126
099-101	Smokey Pink	LEE 127
102-104	Special Med Lavender	LEE 343
105-107	Ultimate Violet	LEE 707
108-110	Magical Magenta	LEE 795
111-113	Chrysalis Pink	LEE 798
114-116	Specia KH Lavender	LEE 799
117-119	Bulb White	2700K
120-122	Halogen White	3200K
123-125	Neutral White	4200K
126-128	Daylight White	5600K
129-131	Cold White I	6000K
132-134	Cold White II	6300K
135-137	White (only if available)	100% White LED
138-140	Amber (only if available)	100% Amber LED
141-143	Lime (only if available)	100% Lime LED
144-146	Cyan (only if available)	100% Cyan LED
147-149	User Color 1	
150-152	User Color 2	
153-155	User Color 3	
156-158	User Color 4	
159-161	User Color 5	
162-164	Color Jumping stop	
165-209	Color Jumping speed slow @ fast	color 1-37
210-255	Color fading speed slow @ fast	color 1-37

Color Macro Chart for Stand Alone

Gels - Color Macros for Standalone Mode		
Position	Gel Name	Color Number
1	Red	100% Red LED
2	Fire	LEE 019
3	Medium Red	LEE 027
4	Primary Red	LEE 106
5	Med Amber	LEE 020
6	Dark Amber	LEE 022
7	Deep Amber	LEE 104
8	Orange	LEE 105
9	Deep Golden Amber	LEE 135
10	Yellow	LEE 101
11	Green	100% Green LED
12	Lime Green	LEE 088
13	Moss Green	LEE 089
14	LEE Green	LEE 121
15	Primary Green	LEE 139
16	Jas Green	LEE 738
17	Jade	LEE 323
18	Blue	100% Blue LED
19	Sky Blue	LEE 068
20	Tokyo Blue	LEE 071
21	Light Blue	LEE 118
22	Marine Blue	LEE 131
23	Med Blue	LEE 132
24	Congo Blue	LEE 181
25	Mikkel Blue	LEE 716
26	Rose Pink	LEE 002
27	Med Pink	LEE 036
28	Light Lavender	LEE 052

Gels - Color Macros for Standalone Mode		
Position	Gel Name	Color Number
29	Lavender	LEE 058
30	Magenta	LEE 113
31	Mauve	LEE 126
32	Smokey Pink	LEE 127
33	Special Med Lavender	LEE 343
34	Ultimate Violet	LEE 707
35	Magical Magenta	LEE 795
36	Chrysalis Pink	LEE 798
37	Specia KH Lavender	LEE 799
38	Bulb White	2700K
39	Halogen White	3200K
40	Neutral White	4200K
41	Daylight White	5600K
42	Cold White I	6000K
43	Cold White II	6300K
44	Amber (only if available)	100% Amber LED
45	Lime (only if available)	100% Lime LED
46	Cyan (only if available)	100% Cyan LED

CTC channel  
DMX / Color temperature

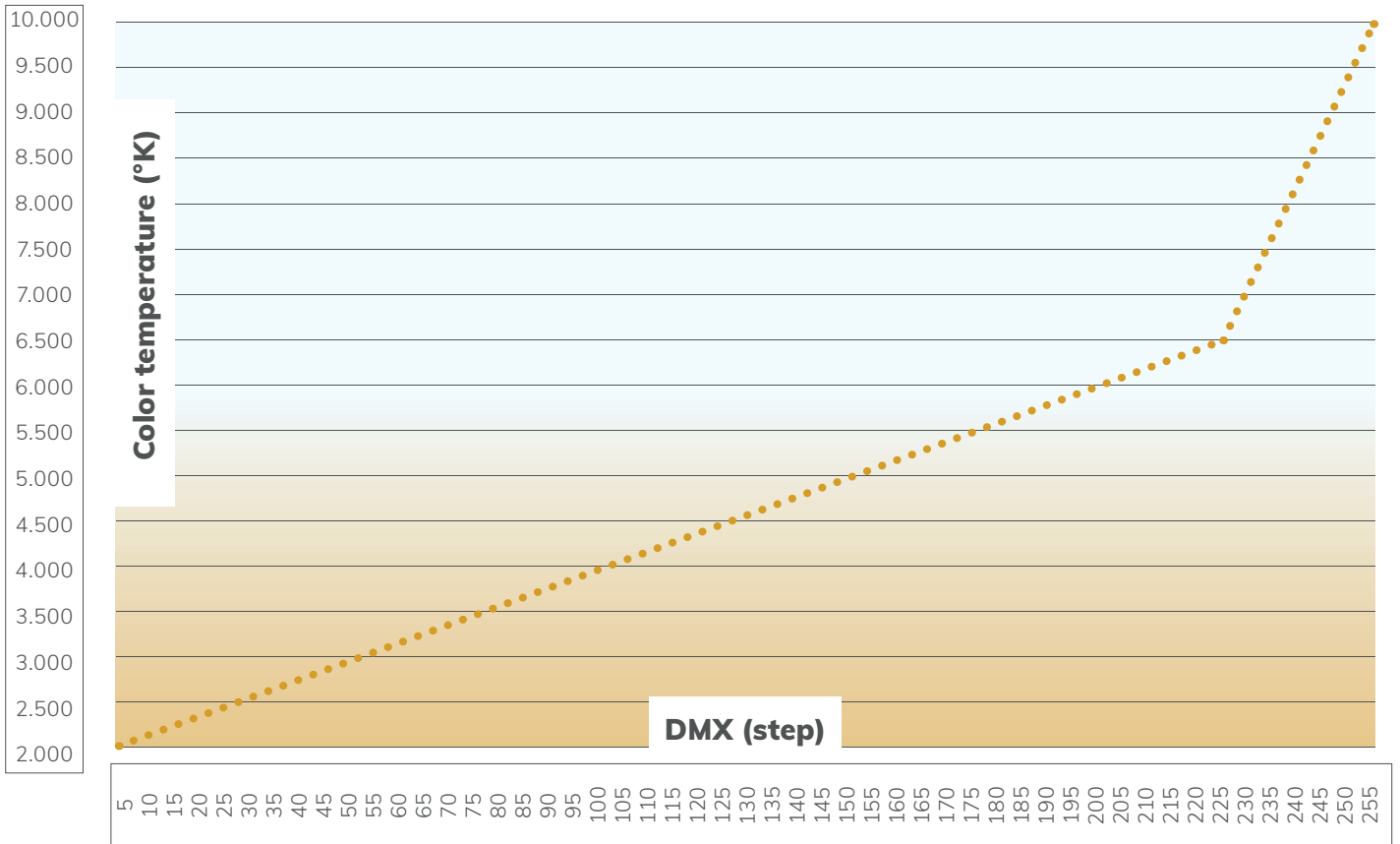

CTC-Chart

DMX (Step)	Color Temp (°K)	DMX (Step)	Color Temp (°K)	DMX (Step)	Color Temp (°K)	DMX (Step)	Color Temp (°K)	DMX (Step)	Color Temp (°K)	DMX (Step)	Color Temp (°K)
0	5600	43	2774	86	3649	129	4525	172	5400	215	6276
1	5600	44	2794	87	3670	130	4545	173	5421	216	6296
2	5600	45	2814	88	3690	131	4566	174	5441	217	6317
3	5600	46	2835	89	3710	132	4586	175	5462	218	6337
4	5600	47	2855	90	3731	133	4606	176	5482	219	6357
5	2000	48	2876	91	3751	134	4627	177	5502	220	6378
6	2020	49	2896	92	3771	135	4647	178	5523	221	6398
7	2041	50	2916	93	3792	136	4667	179	5543	222	6419
8	2061	51	2937	94	3812	137	4688	180	5563	223	6439
9	2081	52	2957	95	3833	138	4708	181	5584	224	6459
10	2102	53	2977	96	3853	139	4729	182	5604	225	6480
11	2122	54	2998	97	3873	140	4749	183	5624	226	6500
12	2143	55	3018	98	3894	141	4769	184	5645	227	6621
13	2163	56	3038	99	3914	142	4790	185	5665	228	6741
14	2183	57	3059	100	3934	143	4810	186	5686	229	6862
15	2204	58	3079	101	3955	144	4830	187	5706	230	6983
16	2224	59	3100	102	3975	145	4851	188	5726	231	7103
17	2244	60	3120	103	3995	146	4871	189	5747	232	7224
18	2265	61	3140	104	4016	147	4891	190	5767	233	7345
19	2285	62	3161	105	4036	148	4912	191	5787	234	7466
20	2305	63	3181	106	4057	149	4932	192	5808	235	7586
21	2326	64	3201	107	4077	150	4952	193	5828	236	7707
22	2346	65	3222	108	4097	151	4973	194	5848	237	7828
23	2367	66	3242	109	4118	152	4993	195	5869	238	7948
24	2387	67	3262	110	4138	153	5014	196	5889	239	8069
25	2407	68	3283	111	4158	154	5034	197	5910	240	8190
26	2428	69	3303	112	4179	155	5054	198	5930	241	8310
27	2448	70	3324	113	4199	156	5075	199	5950	242	8431
28	2468	71	3344	114	4219	157	5095	200	5971	243	8552
29	2489	72	3364	115	4240	158	5115	201	5991	244	8672
30	2509	73	3385	116	4260	159	5136	202	6011	245	8793
31	2529	74	3405	117	4281	160	5156	203	6032	246	8914
32	2550	75	3425	118	4301	161	5176	204	6052	247	9034
33	2570	76	3446	119	4301	162	5197	205	6072	248	9155
34	2590	77	3466	120	4342	163	5217	206	6093	249	9276
35	2611	78	3486	121	4362	164	5238	207	6113	250	9397
36	2631	79	3507	122	4382	165	5258	208	6133	251	9517
37	2652	80	3527	123	4403	166	5278	209	6154	252	9638
38	2672	81	3548	124	4423	167	5299	210	6174	253	9759
39	2692	82	3568	125	4443	168	5319	211	6195	254	9879
40	2713	83	3588	126	4464	169	5339	212	6215	255	10000
41	2733	84	3609	127	4484	170	5360	213	6235		
42	2753	85	3629	128	4505	171	5380	214	6256		

## 7.5 RDM Templates\*

The ROXX Show series features support for various RDM functions.

RDM (Remote Device Management) is a protocol enhancement to USITT DMX512 that allows bi-directional communication between the fixtures and the controller over a standard DMX line. This protocol will allow configuration, status monitoring and management.

You will need a RDM controller to get control over the supported parameters. See the tables below for supported RDM features.

Label:	ROXX CLUSTER B2 FC
Model:	CLUSTER B2 FC
Manufacturer:	ROXX
ID:	6A6Ah
Device ID:	202 xxxx

**ⓘ \*Note: During RDM identifying process CLUSTER B2 FC flashes white to blue color alternately.**

### RDM functions

For easy identifying ROXX CLUSTER B2 FC during RDM process the unit will jump from white color to blue color every second.

PID	Function	Action	Values
0x00F0	DMX Start Adress	Set	001-512
0x00E0	DMX Personality	Set	17x DMX modes
0x00E1	DMX Slots	Read	n.a.
0x8001	Effect	Set	0= Stop Program / 1= Effect 1 / 2= Effect 2 / 3= Effect 3 / 4= Effect 4 / 5= Effect 5 / 6= Effect 6 / 7= Effect 7 / 8= Effect 8 / 9= Effect 9 / 10= Effect 10
0x8002	Effect Dimmer	Set	
0x8003	Effect Speed	Set	
0x8050	Master / Slave	Set	0= Master / 1= Slave
0x0500	Display Flip	Set	0= Off / 1= On
0x8051	Display Backlight	Set	0= Off / 1= On
0x8052	Display Lock	Set	0= Off / 1= On
0x8053	Startup Mode	Set	0= DMX / 1= AUTO / 2= Color Macro / 3= Quick Color / 4= Tunable White / 5=User Color
0x8060	Color Settings	Set	0= Color Calibration / 1= RAW
0x8054	DMX Fail	Set	1= Hold / 2= Blackout / 3= Emergency
0x8055	Dimmer Curve	Set	1= Linear / 2= Exponential / 3= Logarithmic / 4= S-Curve
0x8056	Dimmer Response	Set	1= LED / 2= Medium / 3= Halogen
0x8057	Redshift	Set	0= Off / 1= On
0x8061	Color Calibration	Set	0=CCT Calibration / 1= Full Calibration
0x8058	RAW Balance	Set	0= RAW / 1= User Calibration
0x8020	User Calibration- Red 1	Set	
0x8021	User Calibration- Green 1	Set	
0x8022	User Calibration- Blue 1	Set	
0x8023	User Calibration- Amber 1	Set	
0x8024	User Calibration- White 1	Set	
0x8025	User Calibration- Red 2	Set	

0x8026	User Calibration- Green 2	Set	
0x8027	User Calibration- Blue 2	Set	
0x8028	User Calibration- Amber 2	Set	
0x8029	User Calibration- White 2	Set	
0x8059	LED Frequency (PWM)	Set	1= 800Hz / 2= 1200Hz / 3= 2000Hz / 4= 3600Hz / 5= 12kHz / 6= 25kHz
0x805A	Fan	Set	0= Auto / 1= Silent / 2= Fan Off / 3= Max. Power
0x805B	Invert Mapping	Set	0= On / 1= Off
0x805C	LED Mode	Set	0= Illumination / 1= Boost
delete	USB Update	Yes/No	0= No / 1= Yes
0x805E	Factory Reset	Set	0= No / 1= Yes
0x805F	User Reset	Set	0= No / 1= Yes
0x00C0	Firmware Version	read	n.a.
0x8700	Serial Number	Read	n.a.
0x0400	Device Power on Time	Read	n.a.
0x8701	Temperature LED 1	Read	n.a.
0x8702	Temperature LED 2	Read	n.a.
0x8705	LED 1 on Time	Read	n.a.
0x8706	LED 2 on Time	Read	n.a.

## Sensors

RDM enables various readouts for remote device monitoring. See the table below for sensors and sensor types. Please note: The RDM controller communicates with the fixtures to show only the available sensors for this fixture. The table is subject to change without notice.

Name	
Temperature	xx°C / xxx°F
Software Version	SW-Version
Errors	

## 8. TROUBLESHOOTING

Did you try turning the device off and on again?

Problem	Reason	Solution
Device is not responding.	No power.	Check cable connections and conform that power is switched on.
	Fuse defect.	Contact your qualified service technician / manufacturer.
Device has turned off.	Power failure or power was turned off.	Check power supply, fuse, connections, switches.
Device has stopped responding.	DMX cable correct?	Check cables.
Device operates strangely.	DMX cable inverted (pins correct?)	Use a phase inverter or different cables.
	DMX cable terminated?	If not, install DMX termination at the end of the cable.
	Stand Alone program running?	Stop internal Stand Alone.



## 9. MANUFACTURER'S DECLARATION

### Manufacturer's Warranty & Limitations of Liability

Please find our warranty conditions and limitations of liability inside our manufacturer's declaration at [www.roxxlight.com/support](http://www.roxxlight.com/support)

### Requesting Warranty-Service

To request warranty service for your product, please contact:

ROXX GmbH,

Hansestr. 91

51149 Köln

Email: [info@roxxlight.com](mailto:info@roxxlight.com) or the ROXX authorized reseller in your country, from where you purchased your product.

### Correct Disposal of this product



This is for the European Union and European countries with electrical waste collection systems. When this label is shown on the product or brochure it means that the item cannot be disposed with household waste. In order to prevent damage to the environment or human health please do not dispose this product uncontrolled. Make sure to act responsible, recycle this product separately from other types of waste to enable lasting reuse of resources. Private users please contact the retailer where you purchased this product or your local authorities to find out where and how proper recycling of this item is possible. Business users please contact your supplier or check the terms and conditions of your purchasing contract. Make sure not to mix this product with other commercial waste.

### FCC Statement

This device complies with Part 15 of the FCC Rules. Operation is subject to the following two conditions:

- (1) This device may not cause harmful interference, and
- (2) This device must accept any interference received, including interference that may cause undesired operation

NOTE: This equipment has been tested and found to comply with the limits for a Class B digital device, pursuant to Part 15 of the FCC Rules. These limits are designed to provide reasonable protection against harmful interference in a residential installation. This equipment generates, uses and can radiate radio frequency energy and, if not installed and used in accordance with the instructions, may cause harmful interference to radio communications. However, there is no guarantee that interference will not occur in a particular installation. If this equipment does cause harmful interference to radio or television reception, which can be determined by turning the equipment off and on, the user is encouraged to try to correct the interference by one or more of the following measures:

- Reorient or relocate the receiving antenna.
- Increase the separation between the equipment and receiver.
- Connect the equipment into an outlet on a circuit different from that to which the receiver is connected.
- Consult the dealer or an experienced radio/TV technician for help.

## CE Compliance

The equipment marketed by ROXX GmbH complies (where applicable) with the essential requirements and other specifications of the following Directives:

- 2014/30/EU (EMC)
- 2014/35/EU (LVD)
- 2011/65/EU (RoHS)

The complete EU- and UK-Declaration of Conformity can be found at [www.roxxlight.com/support](http://www.roxxlight.com/support), or you can also request it at [info@roxxlight.com](mailto:info@roxxlight.com)

